

**SUN2000L-(2KTL-5KTL)**

# **User Manual**

**Issue**      **03**  
**Date**        **2018-03-28**

**Copyright © Huawei Technologies Co., Ltd. 2018. All rights reserved.**

No part of this document may be reproduced or transmitted in any form or by any means without prior written consent of Huawei Technologies Co., Ltd.

## **Trademarks and Permissions**



HUAWEI and other Huawei trademarks are trademarks of Huawei Technologies Co., Ltd.

All other trademarks and trade names mentioned in this document are the property of their respective holders.

## **Notice**

The purchased products, services and features are stipulated by the contract made between Huawei and the customer. All or part of the products, services and features described in this document may not be within the purchase scope or the usage scope. Unless otherwise specified in the contract, all statements, information, and recommendations in this document are provided "AS IS" without warranties, guarantees or representations of any kind, either express or implied.

The information in this document is subject to change without notice. Every effort has been made in the preparation of this document to ensure accuracy of the contents, but all statements, information, and recommendations in this document do not constitute a warranty of any kind, express or implied.

# **Huawei Technologies Co., Ltd.**

Address: Huawei Industrial Base  
Bantian, Longgang  
Shenzhen 518129  
People's Republic of China

Website: <http://e.huawei.com>

# About This Document

## Purpose

This document describes the SUN2000L-(2KTL-5KTL) in terms of its installation, electrical connections, commissioning, maintenance, and troubleshooting. SUN2000L-(2KTL-5KTL) is abbreviated as SUN2000L. Before installing and operating the SUN2000L, ensure that you are familiar with the features, functions, and safety precautions provided in this document.





## Intended Audience


This document is intended for:

- Installers
- Users

## Symbol Conventions

The symbols that may be found in this document are defined as follows.

Symbol	Description
 <b>DANGER</b>	Indicates an imminently hazardous situation which, if not avoided, will result in serious injury or death.
 <b>WARNING</b>	Indicates a potentially hazardous situation which, if not avoided, could result in serious injury or death.
 <b>CAUTION</b>	Indicates a potentially hazardous situation which, if not avoided, may result in minor or moderate injury.
 <b>NOTICE</b>	Indicates a potentially hazardous situation which, if not avoided, could result in equipment damage, data loss, performance deterioration, or unanticipated results. NOTICE is used to address practices not related to personal injury.

Symbol	Description
 <b>NOTE</b>	<p>Calls attention to important information, best practices and tips.</p> <p>NOTE is used to address information not related to personal injury, equipment damage, or environment deterioration.</p>

## Change History

Changes between document issues are cumulative. The latest document issue contains all updates made in previous issues.

### Issue 03 (2018-03-28)

- Updated the screenshots in **Quick Setting, Adding/Deleting Devices**.
- Updated the picture and parameters of **Forced Charge/Discharge**.
- Updated the screenshots in **Downloading logs** and **Current log**.
- Added the description about second authentication for operations like **Starting or shutting down the SUN2000L**.
- Updated the sequence of **Device information**.
- Upgraded the FusionHome app to 2.1.11.217.

### Issue 02 (2017-12-12)

- Updated the **Networking application diagram**.
- Updated the **Battery power-on sequence**.
- Upgraded the FusionHome app to 2.1.11.201.

### Issue 01 (2017-09-27)

This issue is used for first office application (FOA).



---

# Contents

---

<b>About This Document</b> .....	<b>ii</b>
<b>1 Safety Precautions</b> .....	<b>1</b>
<b>2 Product Overview</b> .....	<b>5</b>
2.1 Product Introduction .....	5
2.2 Appearance .....	7
2.3 Label Descriptions .....	11
2.4 Working Principles.....	14
<b>3 Storage</b> .....	<b>17</b>
<b>4 System Installation</b> .....	<b>18</b>
4.1 Checking Before Installation .....	18
4.2 Tools and Instruments .....	19
4.3 Determining the Installation Position .....	20
4.4 Installing the Mounting Bracket .....	24
4.4.1 Wall-Mounted Installation .....	25
4.4.2 Support-mounted Installation .....	27
4.5 Installing the SUN2000L.....	29
4.6 Installing the WiFi Antenna .....	33
<b>5 Electrical Connections</b> .....	<b>35</b>
5.1 Preparing Cables.....	36
5.2 Installing the PE Cable .....	39
5.3 Installing the AC Output Power Cable.....	40
5.4 Installing the DC Input Power Cable .....	45
5.5 Installing Battery Cables.....	51
5.6 Installing the Signal Cable.....	53
<b>6 System Commissioning</b> .....	<b>59</b>
6.1 Checking Before Power-On.....	59
6.2 Powering On the System.....	60
6.3 Powering Off the System.....	62
<b>7 Operations on the Local FusionHome App</b> .....	<b>63</b>
7.1 App Overview .....	63

7.2 Downloading and Installing the App .....	65
7.3 Connecting to the SUN2000L WiFi Network .....	65
7.4 App Operations by the Installer .....	69
7.4.1 Logging In to the App .....	69
7.4.2 Querying the SUN2000L Information .....	73
7.4.3 Maintaining the SUN2000L.....	75
7.4.3.1 Adding/Deleting Devices .....	76
7.4.3.2 Upgrading the Device .....	78
7.4.3.3 Energy Control.....	80
7.4.3.3.1 Grid-tied Point Control .....	81
7.4.3.3.2 Energy storage control .....	82
7.4.3.4 IPS Check (for Italy CEI0-21 Grid Code only) .....	85
7.4.3.5 Starting or Shutting Down the SUN2000L .....	87
7.4.3.6 Restoring Factory Defaults .....	88
7.4.3.7 Clearing Data .....	88
7.4.3.8 Adjusting Total Energy Yield .....	89
7.4.3.9 Restart.....	90
7.4.4 Quick Setting .....	90
7.4.5 Setting Grid-Connection Parameters .....	93
7.4.5.1 Grid Parameters .....	94
7.4.5.2 Protection Parameters .....	96
7.4.5.3 Feature Parameters.....	98
7.4.5.4 Power Adjustment.....	104
7.4.5.5 Time setting .....	106
7.4.6 Comm Config .....	108
7.4.7 Managing Logs .....	115
7.4.8 Menu .....	116
7.4.8.1 Changing the Password.....	116
7.4.8.2 About .....	117
7.5 App Operations by the User .....	118
7.5.1 Logging In to the App .....	118
7.5.2 Querying the Device Status .....	119
7.5.3 Alarm Management .....	119
7.5.4 Querying the Power Curve .....	120
7.5.5 Querying Energy Yields.....	121
7.5.6 Settings .....	121
7.5.7 About .....	125
7.6 App Troubleshooting .....	126
<b>8 System Maintenance.....</b>	<b>127</b>
8.1 Routine Maintenance .....	127
8.2 Troubleshooting .....	128

---

<b>9 Handling the SUN2000L .....</b>	<b>135</b>
9.1 Removing the SUN2000L .....	135
9.2 Packing the SUN2000L .....	135
9.3 Disposing of the SUN2000L.....	135
<b>10 Technical Specifications .....</b>	<b>136</b>
<b>A Grid Codes.....</b>	<b>140</b>
<b>B Acronyms and Abbreviations .....</b>	<b>145</b>

---

# 1 Safety Precautions

---

## General Safety



### NOTICE

- Before performing operations, read through this manual and follow all the precautions to prevent accidents. The "DANGER," "WARNING," "CAUTION," and "NOTICE" statements in this document do not represent all the safety instructions. They are only supplements to the safety instructions.
- Only certified electricians are allowed to install, connect cables for, commission, maintain, and troubleshoot Huawei products, and they must understand basic safety precautions to avoid hazards.

---

When operating Huawei equipment, in addition to following the general precautions in this document, follow the specific safety instructions given by Huawei. Huawei will not be liable for any consequence caused by the violation of the safety operation regulations and design, production, and usage standards.

## Disclaimer

Huawei shall not be liable for any consequence caused by any of the following events:

- Damage caused by transportation
- Storage conditions that do not meet the requirements specified in this document
- Incorrect storage, installation, or use
- Installation or use by unqualified personnel
- Failure to comply with the operation instructions and safety precautions in this document
- Operation in extreme environments which are not covered in this document
- Operation beyond specified ranges
- Unauthorized modifications to the product or software code or removal of the product
- Device damage due to force majeure (such as lightning, earthquakes, fire, and storms)
- Warranty expiration without extension of the warranty service
- Installation or use in environments which are not specified in related international standards

## Personnel Requirements

Only certified electricians are allowed to install, connect cables for, commission, maintain, troubleshoot, and replace the SUN2000L. They should:

- Receive professional training.
- Read through this document and follow all the precautions.
- Be familiar with the safety specifications about the electrical system.
- Understand the composition and working principles of the grid-tied PV system and local regulations.
- Wear proper personal protective equipment (PPE).

## Protecting Labels

- Do not scrawl or damage any labels on the SUN2000L enclosure because these labels contain important information about safe operation.
- Do not scrawl or damage the nameplate on the SUN2000L enclosure. This nameplate contains important product information.

## Installation



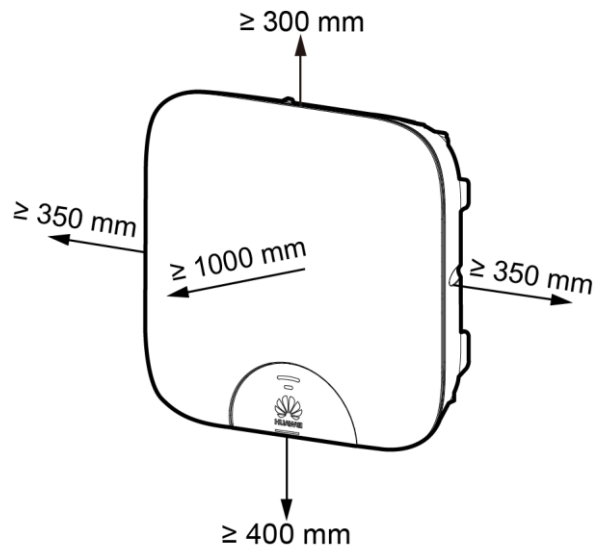
### **DANGER**

Never power on the SUN2000L during installation.

---

- Ensure that the SUN2000L is not connected to a power supply or powered on before installation is complete.
- To allow proper heat dissipation and installation, maintain appropriate clearances between the SUN2000L and other objects, as shown in [Figure 1-1](#). If you have any questions about the clearances, consult technical support engineers.

**Figure 1-1** Installation clearances



- Ensure that the SUN2000L is installed in a well-ventilated environment.
- Ensure that the SUN2000L heat sinks are free from blockage.
- Do not open the front panel of the SUN2000L.
- Do not remove the terminals and ports at the bottom of the SUN2000L.

## Electrical Connections



Before connecting cables, ensure that the SUN2000L is secured in position and not damaged in any way. Otherwise, electric shocks or fire may occur.

- Ensure that all electrical connections comply with the local electrical standards.
- Obtain approval from the local utility company before using the SUN2000L to generate electricity in grid-tied mode.
- Ensure that the cables used in a grid-tied PV system are properly connected and insulated and meet all specification requirements.

## Operation



## DANGER

The high voltage generated by the SUN2000L during operation may cause an electric shock, which can result in serious property damage, serious injury, or death. Strictly comply with the safety precautions in this document and associated documents when operating the SUN2000L.

- When the SUN2000L is powered on for the first time, only certified electricians are allowed to perform quick setting. Incorrect settings may affect the normal SUN2000L operation and cause the SUN2000L to not comply with the country certification.
- When the SUN2000L is operating, do not disconnect under load.
- Do not touch an energized SUN2000L because the heat sink reaches a high temperature.
- Follow local laws and regulations when operating the equipment.

## Maintenance and Replacement



## DANGER

The high voltage generated by the SUN2000L during operation may cause an electric shock, which can result in serious property damage, serious injury, or death. Prior to maintenance, power off the SUN2000L and strictly comply with the safety precautions in this document and associated documents to operate the SUN2000L.

- Before performing maintenance on the SUN2000L, ensure that you have sufficient knowledge of this document, and proper tools and testing equipment.
- Before performing maintenance tasks, power off the SUN2000L and wait at least 5 minutes.
- Temporary warning signs or fences must be placed to prevent unauthorized people from entering the site.
- If the SUN2000L is faulty, contact your supplier.
- The SUN2000L can be powered on only after all faults are rectified. Failing to do so may escalate faults or damage the device.
- Observe ESD precautions and wear ESD gloves during maintenance.

# 2 Product Overview

## 2.1 Product Introduction

### Function

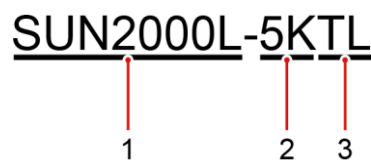
The SUN2000L is a single-phase grid-tied PV string inverter that converts the DC power generated by PV strings into AC power and feeds the electricity into the power grid.

### Models

This document involves the following product models:

- SUN2000L-2KTL
- SUN2000L-3KTL
- SUN2000L-3.68KTL
- SUN2000L-4KTL
- SUN2000L-4.6KTL
- SUN2000L-5KTL

**Figure 2-1** Designation explanation of the SUN2000L-5KTL



**Table 2-1** Designation explanation of the SUN2000L-5KTL

No.	Meaning	Description
1	Series name	SUN2000L: single-phase grid-tied PV string inverter

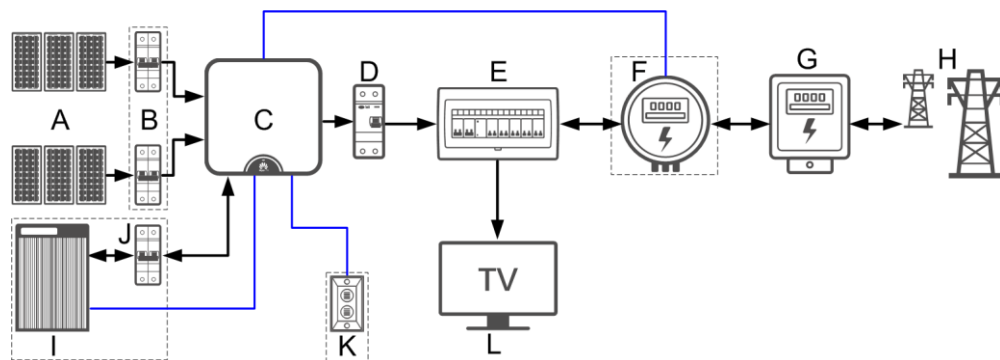


No.	Meaning	Description
2	Power level	<ul style="list-style-type: none"> <li>• 2K: The power level is 2K.</li> <li>• 3K: The power level is 3K.</li> <li>• 3.68K: The power level is 3.68K.</li> <li>• 4K: The power level is 4K.</li> <li>• 4.6K: The power level is 4.6K.</li> <li>• 5K: The power level is 5K.</li> </ul>
3	Topology	TL: transformerless

## Networking Application

The SUN2000L applies to a residential rooftop grid-tied system. Typically, a grid-tied system consists of the PV string, grid-tied inverter, AC switch, and power distribution unit.

**Figure 2-2** Network diagram (dashed boxes indicate optional components)



### NOTE

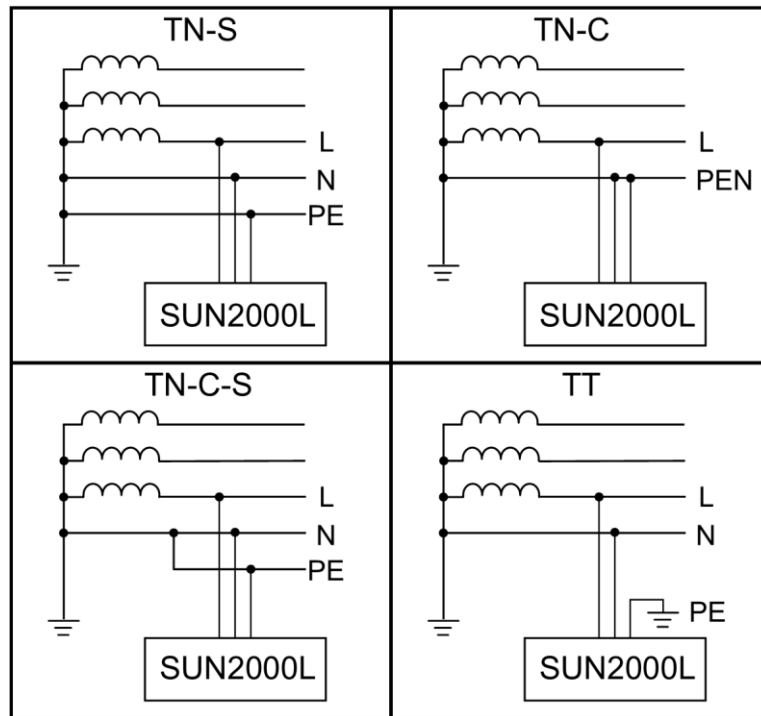
— indicates a power cable, → indicates the power flow direction, and — indicates a signal cable.

- |                    |                             |                      |
|--------------------|-----------------------------|----------------------|
| (A) PV string      | (B) DC switch               | (C) SUN2000L         |
| (D) AC switch      | (E) Power distribution unit | (F) Energy meter     |
| (G) Power meter    | (H) Power grid              | (I) Battery          |
| (J) Battery switch | (K) Alarm beacon            | (L) Residential load |

## Supported Power Grid

The power grids supported by the SUN2000L include TN-S, TN-C, TN-C-S, and TT. In a TT power grid, the N-PE voltage should be lower than 30 V.

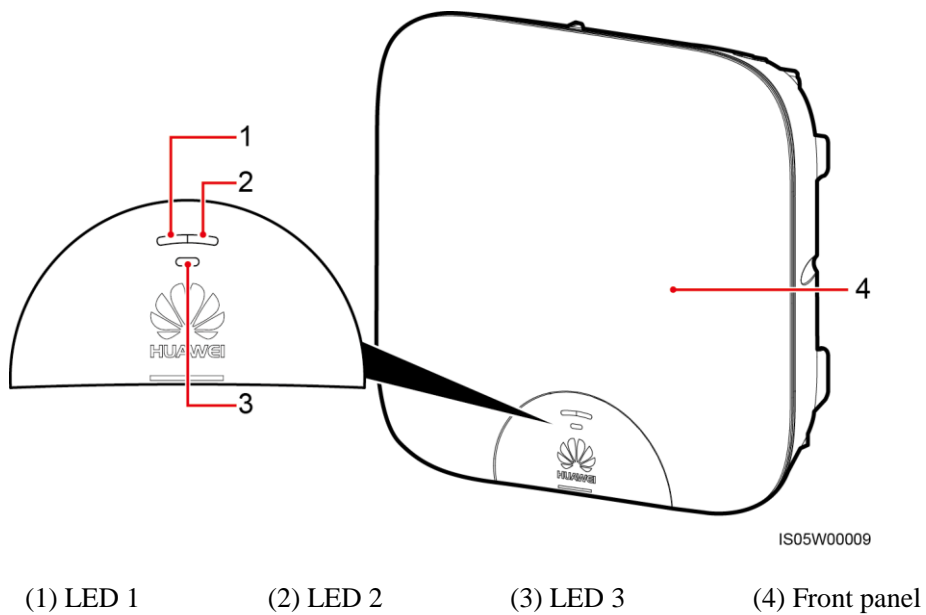
**Figure 2-3** Power grid types



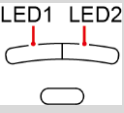
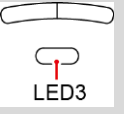
## 2.2 Appearance

### Front View

**Figure 2-4** Front view

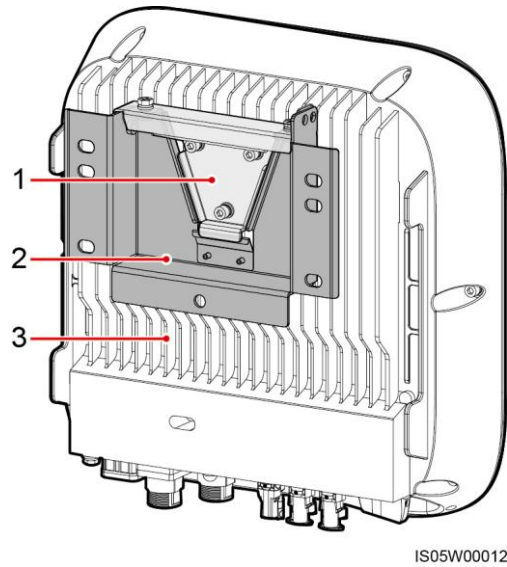


**Table 2-2** LED description

Type	Status		Meaning
<b>Running indication</b> 	<b>LED 1</b>	<b>LED 2</b>	N/A
	Steady green	Steady green	The SUN2000L is exporting power to the power grid.
	Blinking green at long intervals (on for 1s and then off for 1s)	Off	The DC is on and the AC is off.
	Off	Blinking green at long intervals (on for 1s and then off for 1s)	The DC is off and the AC is on.
	Blinking green at long intervals (on for 1s and then off for 1s)	Blinking green at long intervals (on for 1s and then off for 1s)	The DC is on, the AC is on, and the SUN2000L is not exporting power to the power grid.
	Off	Off	Both the DC and AC are off, or the SUN2000L is in Low Power Consumption mode. Low Power Consumption mode means that the monitoring system of the SUN2000L is hibernating.
	Steady red	Steady red	The SUN2000L is faulty.
<b>Communication indication</b> 	<b>LED 3</b>		N/A
	Blinking green at short intervals (on for 0.2s and then off for 0.2s)		Communicating (Communicating means that the communication with the upper-level management unit is in progress. However, if a mobile phone accesses the SUN2000L, the LED indicates the "mobile phone access status: blinking green at long intervals" first.)
	Blinking green at long intervals (on for 1s and then off for 1s)		The mobile phone is connected to the SUN2000L.
Off		No communication	

## Rear View

Figure 2-5 Rear view



IS05W00012

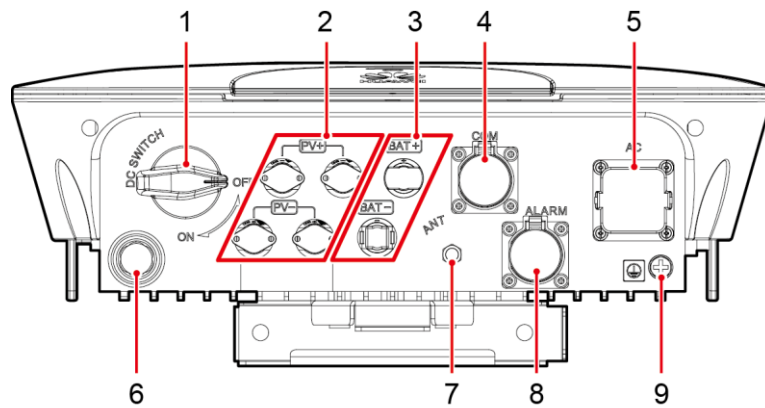
(1) Mounting plate

(2) Mounting bracket

(3) Heat sink

## Bottom View

Figure 2-6 Bottom view



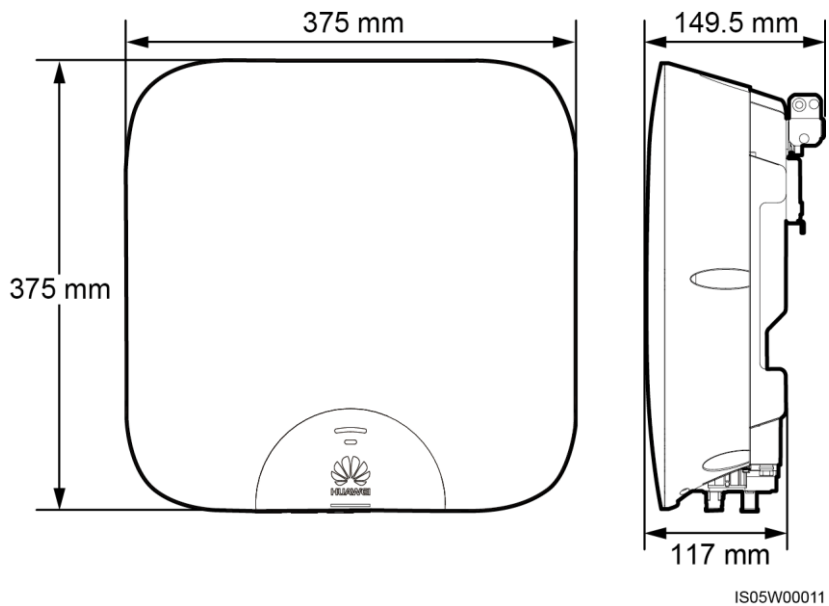
IS05W00010

No.	Component	Silk Screen
1	DC switch	DC SWITCH
2	DC input terminal	PV+/PV-
3	Battery terminal	BAT+/BAT-

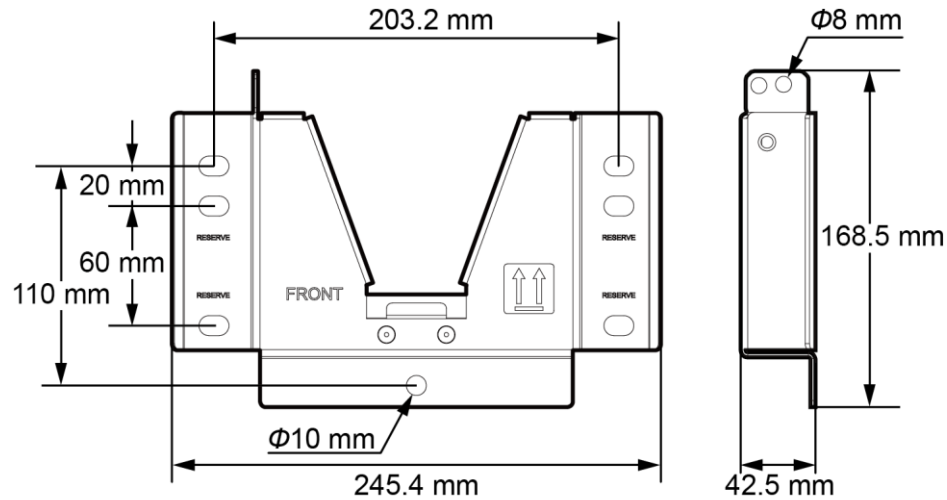
No.	Component	Silk Screen
4	COM port	COM
5	AC output port	AC
6	Ventilation valve	N/A
7	Antenna port	ANT
8	Alarm port	ALARM
9	Ground point	N/A

## Dimensions

Figure 2-7 Enclosure dimensions



**Figure 2-8** Mounting bracket dimensions





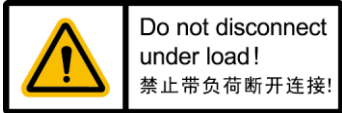




IS05W00020


## 2.3 Label Descriptions

### Labels

**Table 2-3** Label description

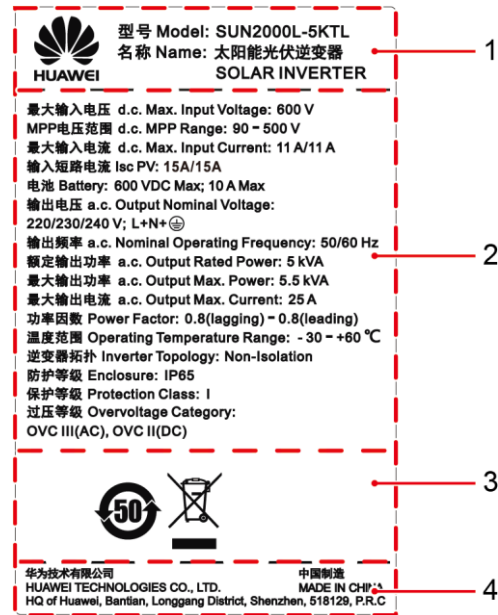
Symbol	Name	Meaning
	Burn warning	Do not touch a running SUN2000L because the shell is hot when the SUN2000L is running.
	Delay discharge	<ul style="list-style-type: none"> <li>High voltage exists after the SUN2000L is powered on. Only qualified and trained electrical technicians are allowed to perform operations on the SUN2000L.</li> <li>Residual voltage exists after the SUN2000L is powered off. It takes 5 minutes for the SUN2000L to discharge to the safe voltage.</li> </ul>

Symbol	Name	Meaning
	Refer to documentation	Reminds operators to refer to the documents supplied with the SUN2000L.
	Grounding	Indicates the position for connecting the protective earthing (PE) cable.
	Operation warning	Do not remove the connector or antenna when the SUN2000L is running.
	Indicator status description label	Describes the indicator status.
 SN: xxxxxxxxxxxxxxxxxxxxxx	SUN2000L serial number (SN) label	Indicates the SUN2000L SN.
 MAC: xxxxxxxxxxxxxx	SUN2000L MAC address label	Indicates the MAC address.
	QR code for SUN2000L WiFi connection	Scan the QR code to connect to Huawei SUN2000L WiFi network (Android) or obtain the WiFi password (iOS).

 **NOTE**  
The labels are for reference only.

## Nameplate

Figure 2-9 Nameplate



- (1) Trademark and product model
- (2) Important technical specifications
- (3) Compliance symbols
- (4) Company name and country of manufacture

**NOTE**

The nameplate figure is for reference only.

Table 2-4 Compliance symbols

Symbol	Name	Meaning
	Environment friendly use period (EFUP) mark	The product does not pollute the environment during the specified period.
	EU waste electrical and electronic equipment (WEEE) mark	Do not dispose of the product as household garbage.



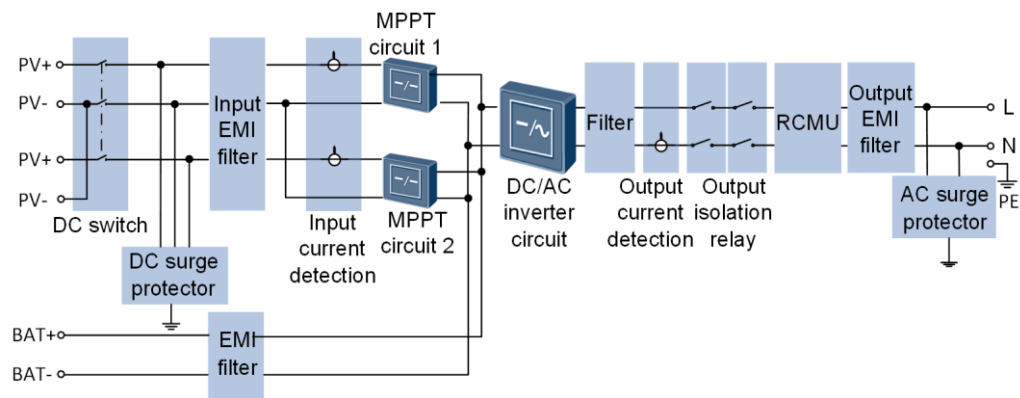
## 2.4 Working Principles

### Conceptual Diagram

The SUN2000L receives two inputs from the two PV strings. Two MPPT circuits are configured inside the SUN2000L. Each circuit tracks the maximum power point of one PV string respectively. The DC power is then converted into single-phase AC power through an inverter circuit. Surge protection is supported on both the DC and AC sides.

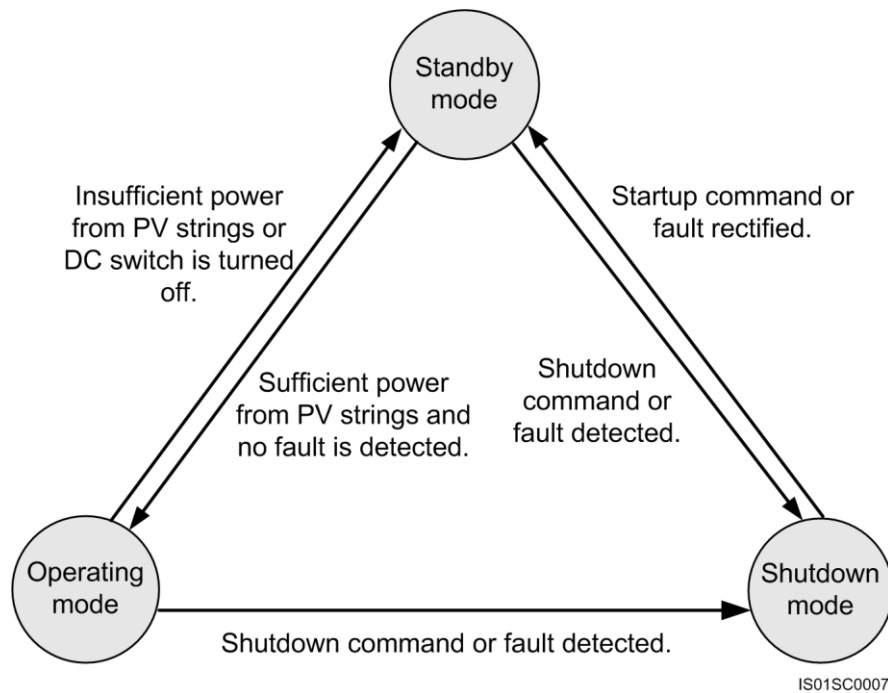
The SUN2000L has a reserved battery port to connect to batteries, which are used to store the surplus power produced by PV strings and not required by residential loads. The power stored in batteries can be exported to the power grid based on the load condition to meet peak and valley power consumption requirements and maximize the benefits.

**Figure 2-10** Conceptual diagram



## Working Modes

**Figure 2-11** Working modes



**Table 2-5** Working mode description

Working Mode	Description
Standby	<p>The SUN2000L enters Standby mode when the external environment does not meet the requirements for starting the SUN2000L. In Standby mode:</p> <ul style="list-style-type: none"> <li>The SUN2000L continuously checks its status and enters Operating mode once the operating requirements are met.</li> <li>The SUN2000L enters Shutdown mode after detecting a shutdown command or a fault after startup.</li> </ul>
Operating	<p>In Operating mode:</p> <ul style="list-style-type: none"> <li>The SUN2000L converts DC power from PV strings into AC power and feeds the energy to the power grid.</li> <li>The SUN2000L tracks the maximum power point to maximize the PV string output.</li> <li>The SUN2000L enters Shutdown mode after detecting a fault or a shutdown command, and enters Standby mode after detecting that the PV string output power is not suitable for connecting to the power grid and producing power.</li> </ul>

<b>Working Mode</b>	<b>Description</b>
Shutdown	<ul style="list-style-type: none"><li>• In Standby or Operating mode, the SUN2000L enters Shutdown mode after detecting a fault or shutdown command.</li><li>• In Shutdown mode, the SUN2000L enters Standby mode after detecting a startup command or that the fault is rectified.</li></ul>

# 3 Storage

---

The following requirements should be met when the SUN2000L needs to be stored prior to installation:

- Do not unpack the SUN2000L.
- Keep the storage temperature at  $-40\text{ }^{\circ}\text{C}$  to  $+70\text{ }^{\circ}\text{C}$  and the humidity at 5%–95% RH.
- The SUN2000L should be stored in a clean and dry place and be protected from dust and water vapor corrosion.
- A maximum of 10 SUN2000Ls can be stacked. To avoid personal injury or device damage, stack SUN2000Ls with caution to prevent them from falling over.
- Regular inspection is required during the storage. Replace the packing materials when necessary.
- After long-term storage, the SUN2000L needs to be inspected and tested by qualified persons before it is put into use.

---

# 4 System Installation

---

## 4.1 Checking Before Installation

### Outer Packing Materials

Before unpacking the SUN2000L, check the outer packing materials for damage, such as holes and cracks, and check the SUN2000L model. If any damage is found or the SUN2000L model is not what you requested, do not unpack the product and contact your supplier as soon as possible.



### NOTICE

You are advised to remove the packing materials no more than 24 hours before installing the SUN2000L.

---

### Package Contents

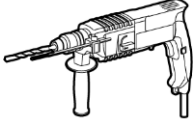
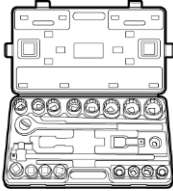
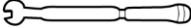
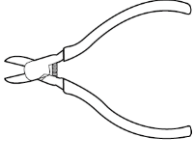
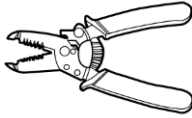
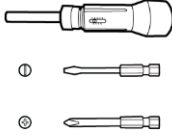



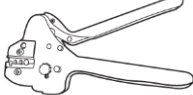




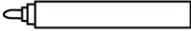
After unpacking the SUN2000L, check that the contents are intact and complete. If any damage is found or any component is missing, contact your supplier.

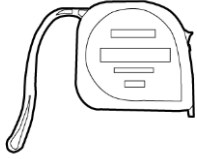

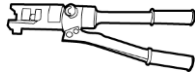
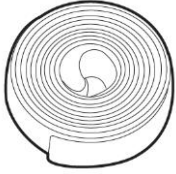







### NOTE

For details about the number of contents, see the *Packing List* in the packing case.

## 4.2 Tools and Instruments

Category	Tools and Instruments		
Installation			
	Hammer drill (with a $\Phi 10$ mm drill bit)	Torque socket wrench (open end: 13 mm, applicable for M8 bolts; torque range: 0–15 N•m)	Torque wrench (open end: 13 mm; torque range: 0–1.5 N•m)
			
	Diagonal pliers	Wire stripper	Torque screwdriver (head: M4 or M6; torque range: 0–5 N•m)
			
Rubber mallet	Utility knife	Cable cutter	
			
Crimping tool (model: H4TC0001; manufacturer: Amphenol)	Open-end wrench (model: H4TW0001; manufacturer: Amphenol)	Cable tie	
			
Vacuum cleaner	Multimeter (DC voltage measurement range $\geq 600$ V DC)	Marker	

Category	Tools and Instruments		
	 Measuring tape	 Bubble or digital level	 Hydraulic pliers
	 Heat shrink tubing	 Heat gun	N/A
PPE	 Safety gloves	 Safety goggles	 Anti-dust respirator
	 Safety shoes	N/A	N/A

## 4.3 Determining the Installation Position

### Basic Requirements

- The SUN2000L is protected to IP65 and can be installed indoors or outdoors.
- Do not install the SUN2000L in a place where a person can easily touch it because its enclosure and heat sinks are extremely hot during operation.
- Do not install the SUN2000L in areas with flammable or explosive materials.
- Do not install the SUN2000L at a place within children's reach.
- Do not install the SUN2000L outdoors in salt areas because it will be corroded there and may cause fire. A salt area refers to the region within 500 meters from the coast or prone to sea breeze. The regions prone to sea breeze vary depending on weather conditions (such as typhoons and monsoons) or terrains (such as dams and hills).

## Installation Environment Requirements

- The SUN2000L must be installed in a well-ventilated environment to ensure good heat dissipation.
- When installed under direct sunlight, the power of the SUN2000L may be derated due to additional temperature rise.
- Install the SUN2000L in a sheltered place or install an awning over the SUN2000L.

## Mounting Structure Requirements

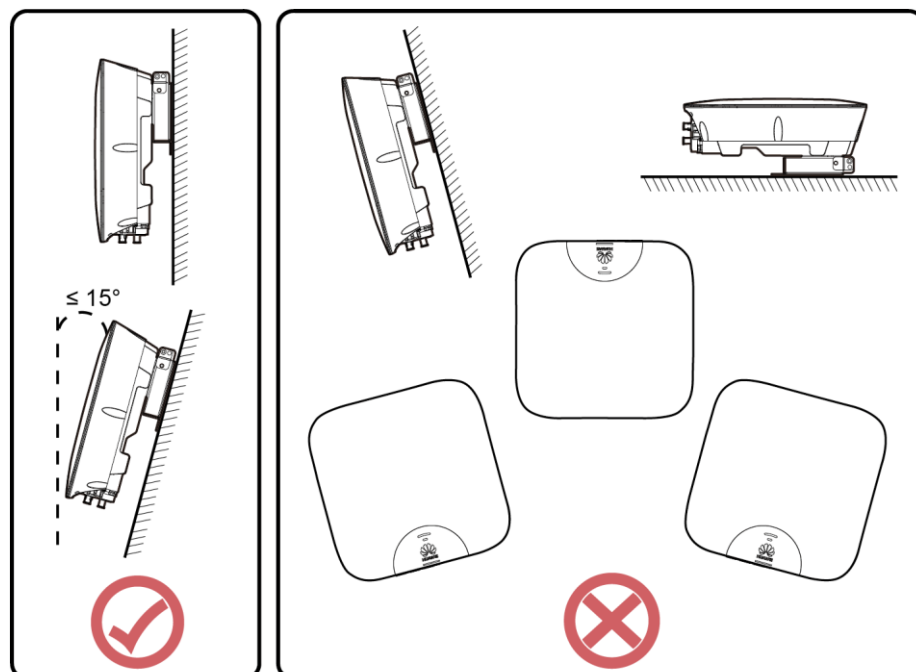
- The mounting structure where the SUN2000L is installed must be fireproof.
- Do not install the SUN2000L on flammable building materials.
- Ensure that the installation surface is solid enough to bear the weight load.
- In residential areas, do not install the SUN2000L on drywalls or walls made of similar materials which have a weak sound insulation performance because the noise generated by the SUN2000L is noticeable.

## Installation Angle Requirements

The SUN2000L can be wall-mounted or pole-mounted. The installation angle requirements are as follows:

- Install the SUN2000L vertically or at a maximum back tilted angle of 15 degrees to facilitate heat dissipation.
- Do not install the SUN2000L at forward tilted, excessively back tilted, side tilted, horizontal, or upside down positions.

**Figure 4-1** Installation angle



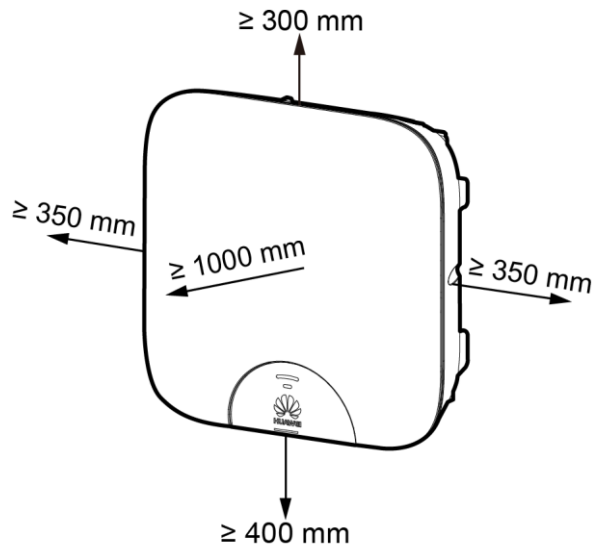
IS05W00014



## Installation Clearance Requirements

- Reserve enough clearance around the SUN2000L to ensure sufficient space for installation and heat dissipation.

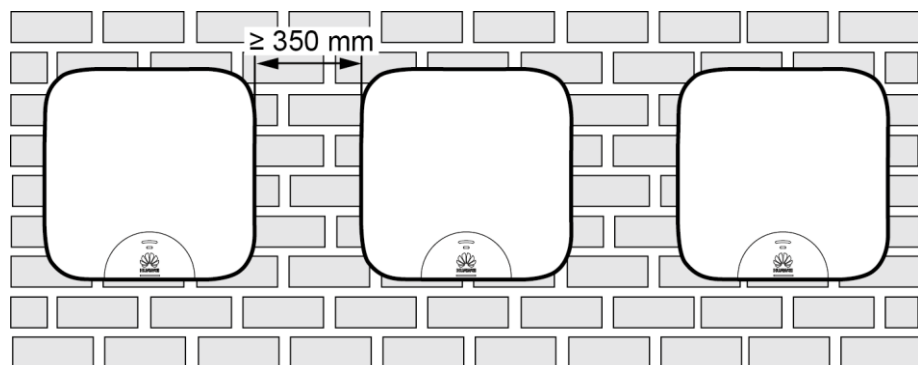
**Figure 4-2** Installation clearance requirements



IS05W00019

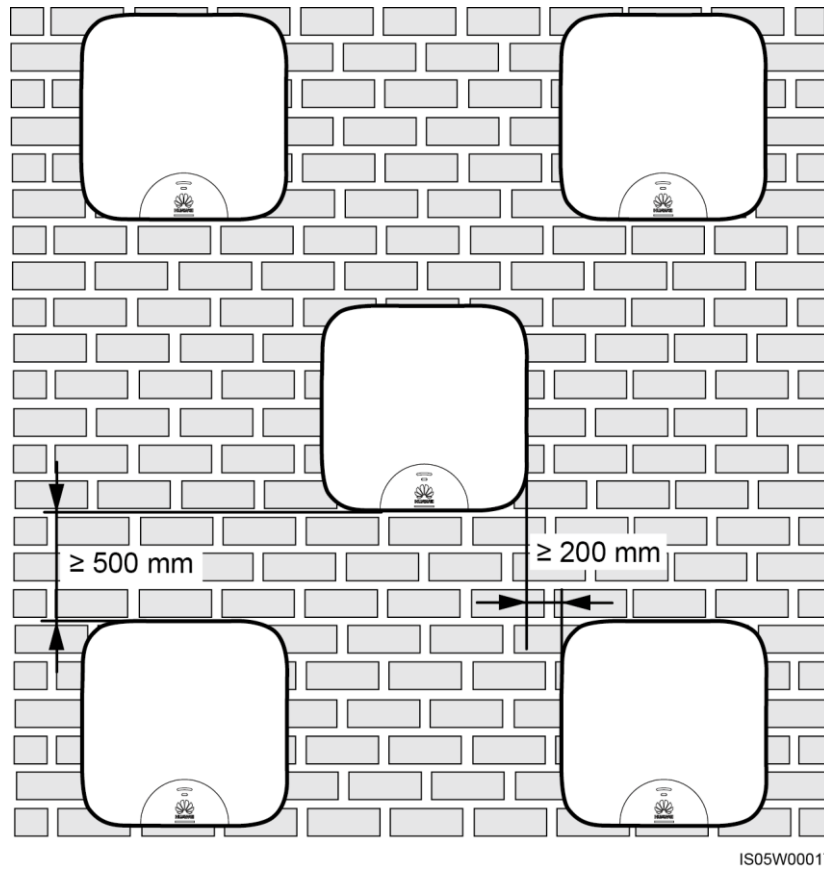
- When installing multiple SUN2000Ls, install them in horizontal mode if the space is sufficient and install them in staggered mode if the space is insufficient. Stacked installation is not recommended.

**Figure 4-3** Horizontal installation mode (recommended)

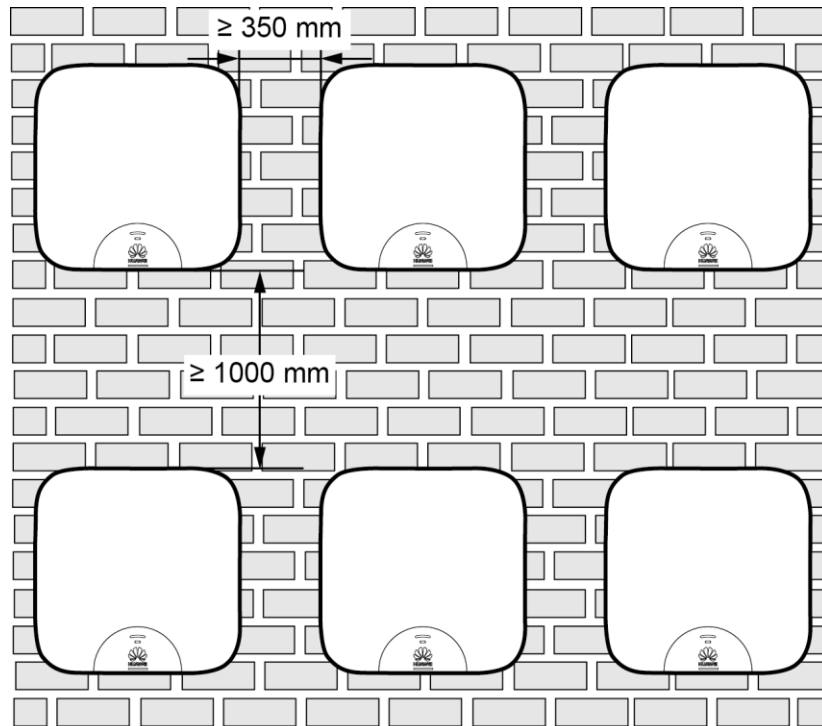


IS05W00015

**Figure 4-4** Staggered installation mode (recommended)



**Figure 4-5** Stacked installation mode (not recommended)

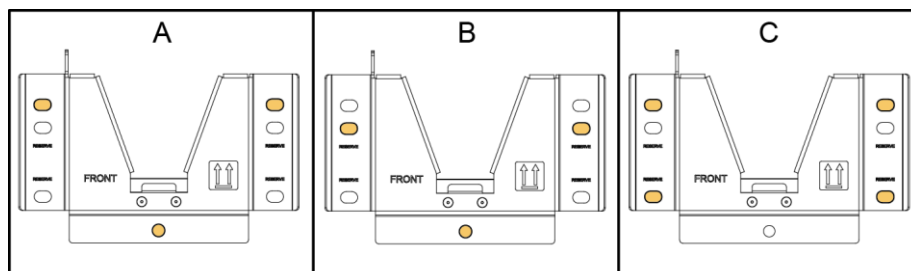


IS05W00016

## 4.4 Installing the Mounting Bracket

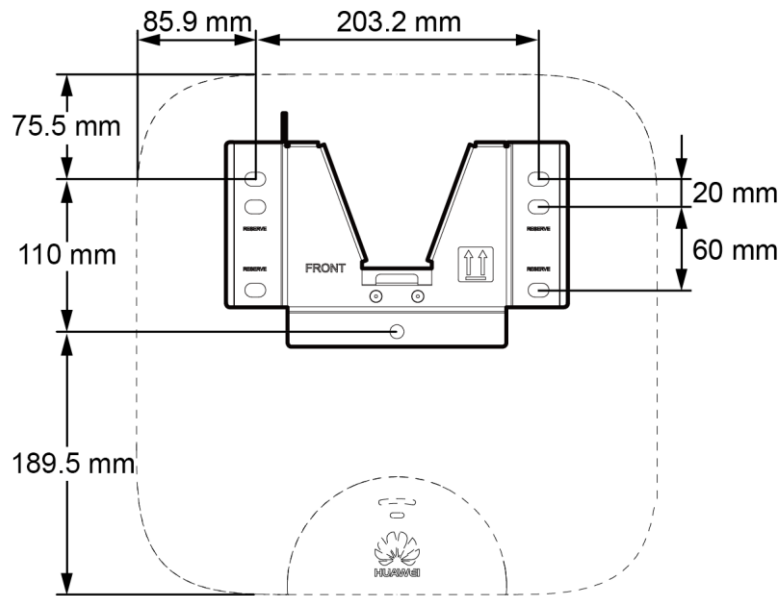
Fixing holes can be used in three combinations. Select a hole combination based on site requirements. Combination A is preferred.

**Figure 4-6** Hole combinations



IS05W00027

**Figure 4-7** Hole distances



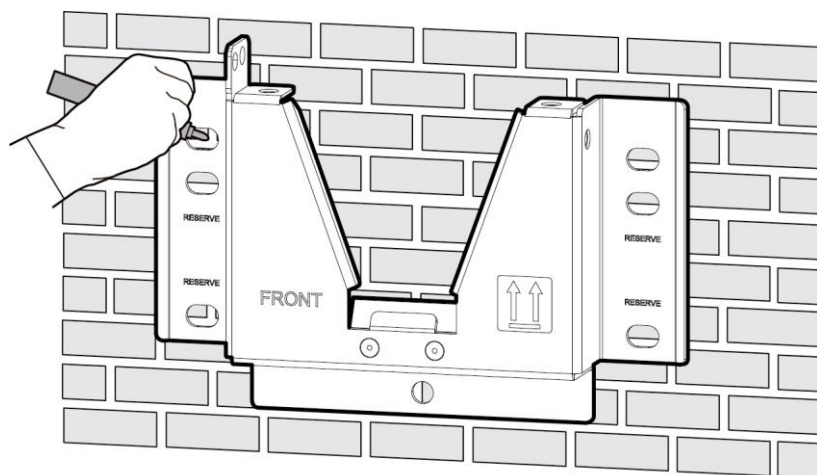
IS05W00021

## 4.4.1 Wall-Mounted Installation

### Procedure

- Step 1** Determine the positions for drilling holes using the mounting bracket. Level the positions of mounting holes using a bubble or digital level, and mark the positions with a marker.

**Figure 4-8** Determining hole positions



IS05H00017

- Step 2** Install expansion bolts.

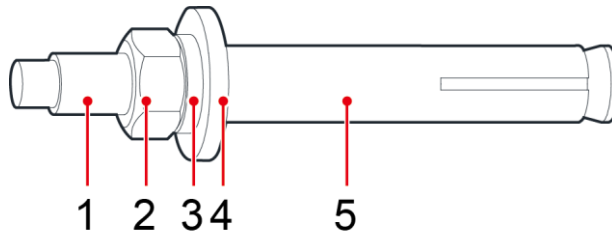
 **DANGER**

Avoid drilling holes in the utility pipes and/or cables attached to back of the wall.

 **NOTE**

If the length or number of M8x80 expansion bolts supplied with the SUN2000L is not enough, prepare M8 stainless steel expansion anchor bolts.

**Figure 4-9** Expansion bolt composition



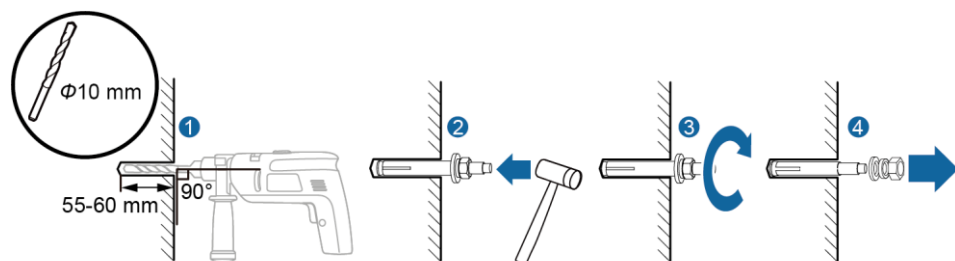
IS05W00018

- |                 |                      |                   |
|-----------------|----------------------|-------------------|
| (1) Bolt        | (2) Nut              | (3) Spring washer |
| (4) Flat washer | (5) Expansion sleeve |                   |

 **NOTICE**

- To prevent dust inhalation or contact with eyes, wear safety goggles and an anti-dust respirator when drilling holes.
- Clean up any dust in and around the holes using a vacuum cleaner and measure the distance between holes. If the holes are inaccurately positioned, drill a new set of the holes.
- Level the head of the expansion sleeve with the concrete wall after removing the bolt, spring washer, and flat washer. Otherwise, the mounting bracket will not be securely installed on the concrete wall.

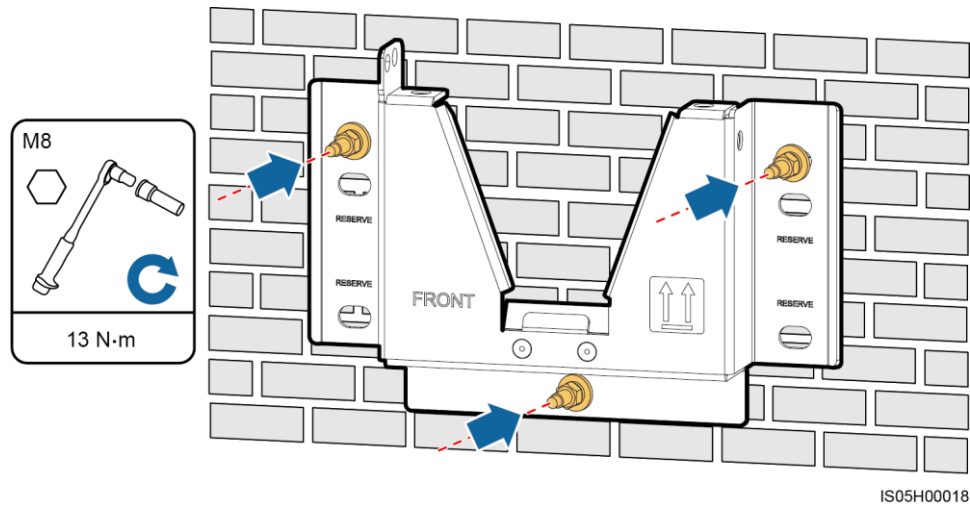
**Figure 4-10** Installing an expansion bolt



IS05H00021

**Step 3** Secure the mounting bracket.

**Figure 4-11** Securing a mounting bracket



----End

## 4.4.2 Support-mounted Installation

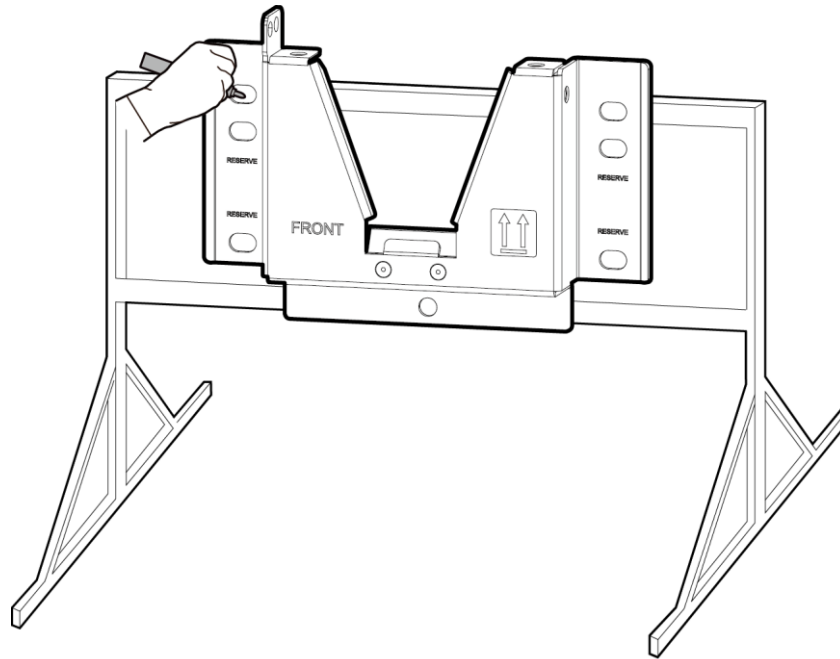
### Prerequisites

Prepare M8 stainless bolt assemblies (including flat washers, spring washers, and M8 bolts) with appropriate lengths as well as matched flat washers and nuts based on the support specifications.

### Procedure

- Step 1** Determine the positions for drilling holes using the mounting bracket. Level the positions of mounting holes using a bubble or digital level, and mark the positions with a marker.

**Figure 4-12** Determining hole positions



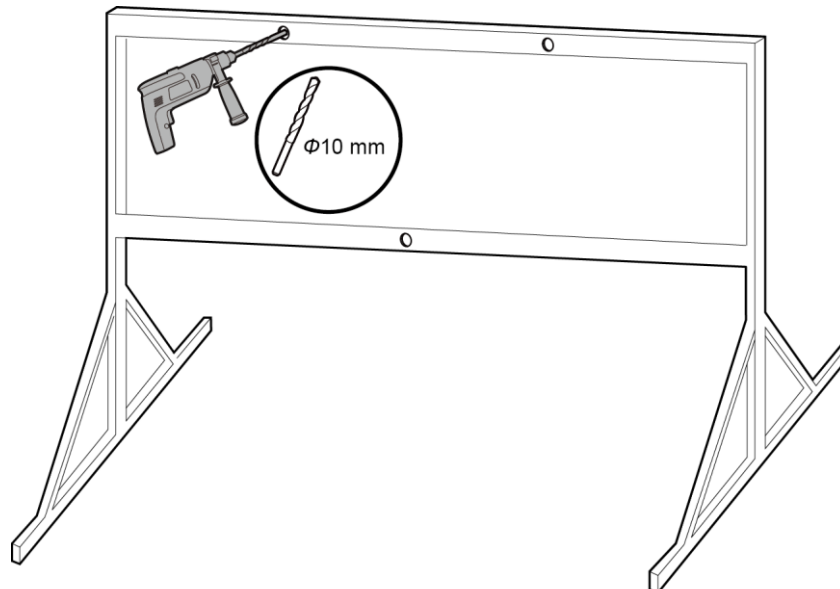
IS05H00020

**Step 2** Drill holes using a hammer drill.

 **NOTE**

You are advised to apply anti-rust paint on the hole positions for protection.

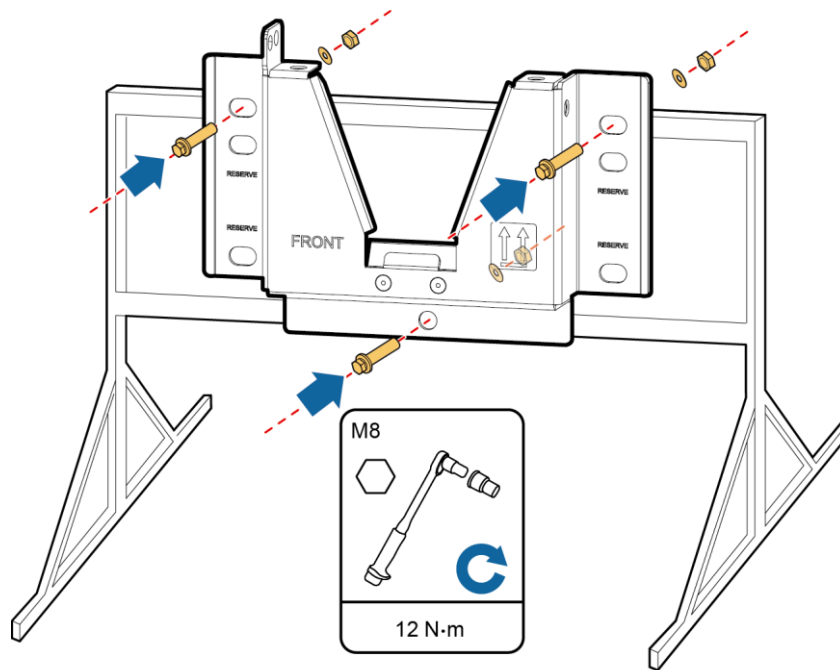
**Figure 4-13** Drilling holes



IS05H00022

**Step 3** Secure the mounting bracket.

**Figure 4-14** Securing a mounting bracket



IS05H00023

----End

## 4.5 Installing the SUN2000L

### Procedure

- Step 1** Hold the handles on both sides of the SUN2000L, lift the SUN2000L from the packing case, and move it to the installation position.

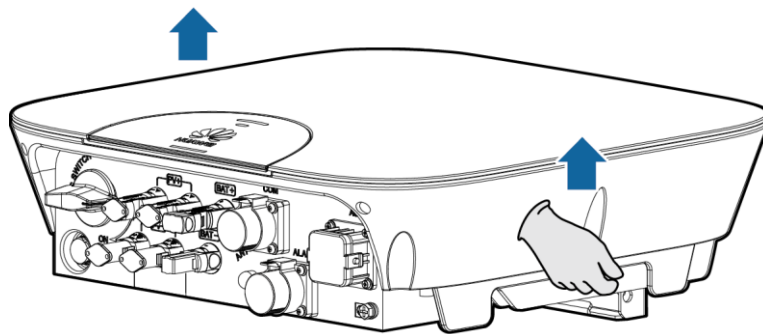


---

 **CAUTION**

- To prevent device damage and personal injury, keep balance when moving the SUN2000L.
  - Do not use the wiring terminals and ports at the bottom to support any weight of the SUN2000L.
  - When you need to temporarily place the SUN2000L on the ground, use foam, paper or other protection materials to prevent damage to its cover.
- 

**Figure 4-15** Moving a SUN2000L



IS05H00019

- Step 2** Install the SUN2000L on the mounting bracket and align the SUN2000L enclosure with the mounting bracket.

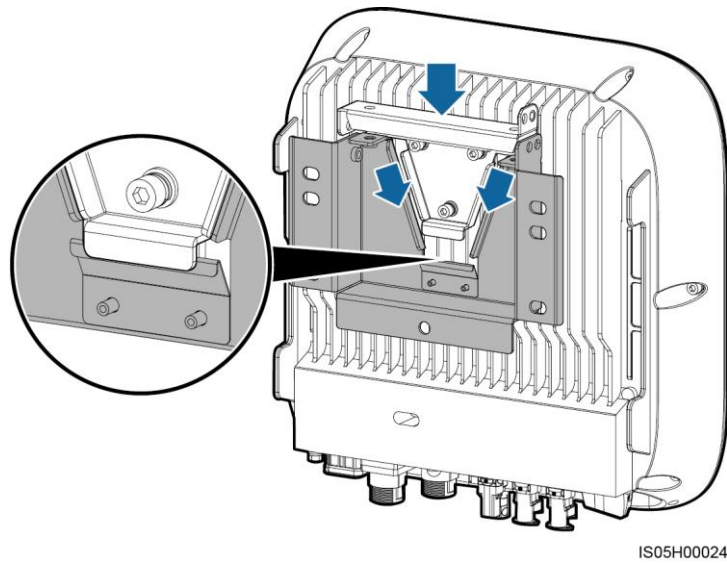
---

 **NOTICE**

If the bottom of the mounting plate does not snap into place, push the SUN2000L from the front until the bottom of the mounting plate snaps into the mounting bracket.

---

**Figure 4-16** Mounting a SUN2000L

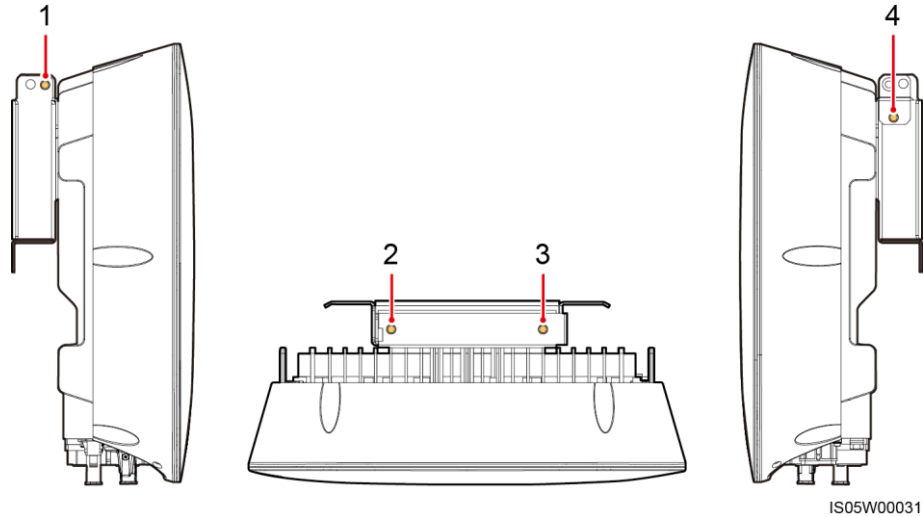


IS05H00024

**Step 3** Tighten screw assemblies.

Fixing holes can be used in three combinations. Select a hole combination based on site requirements. Combination A is preferred.

**Figure 4-17** Fixing holes



IS05W00031

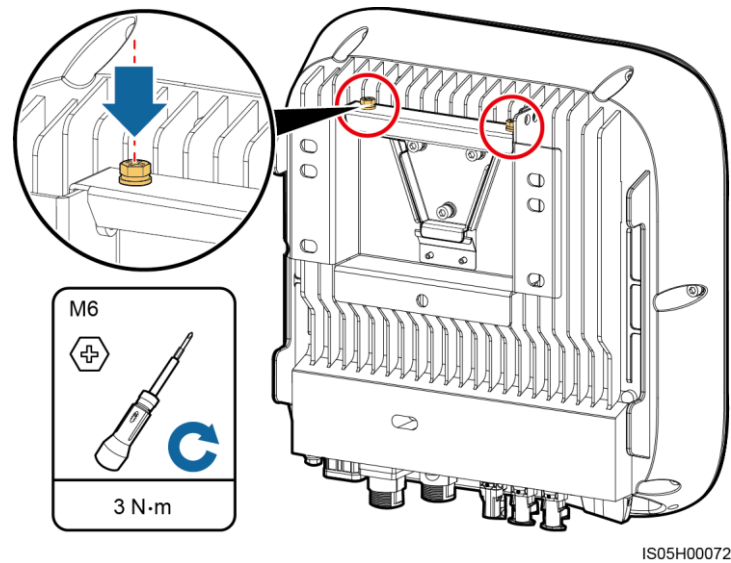
Combination A: holes 2 and 3

Combination B: holes 1 and 3

Combination C: holes 1 and 4

Combination D: holes 2 and 4

**Figure 4-18** Tightening screw assemblies



**Step 4** (Optional) Install an anti-theft lock.

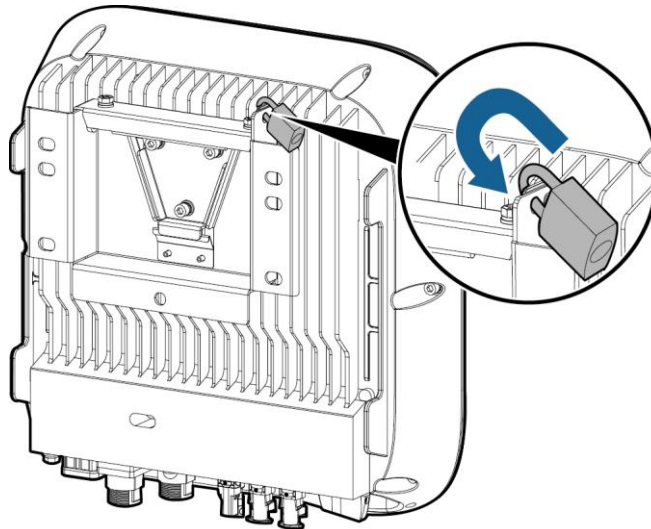
The function of an anti-theft lock is to secure the SUN2000L to the mounting bracket and protect it from being stolen.



## NOTICE

- Use an anti-theft lock suitable for the lock hole diameter ( $\Phi 8$  mm). The anti-theft lock is supplied by the customer.
- Keep the key to the anti-theft lock safe.

**Figure 4-19** Installing an anti-theft lock



IS05H00073

----End

## 4.6 Installing the WiFi Antenna

### Procedure

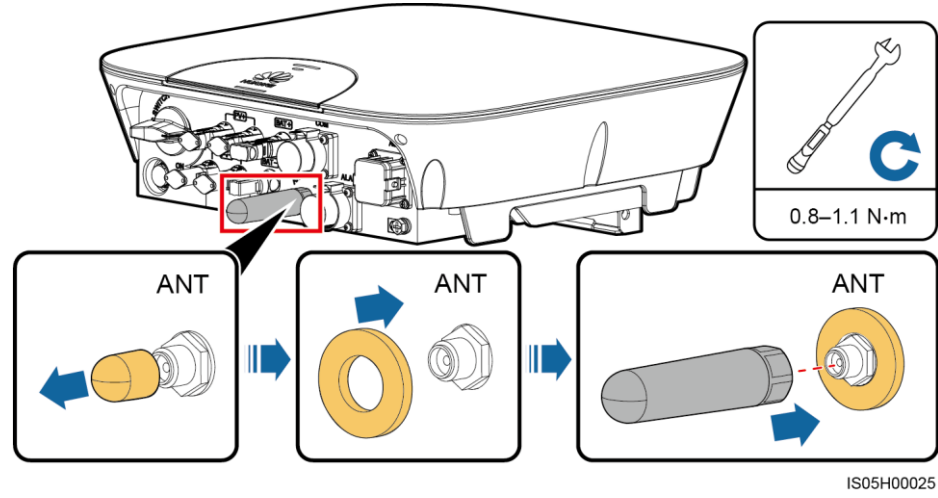
- Step 1** Remove the watertight cap from the ANT port.
- Step 2** Remove the release paper of the double-sided tape and attach the washer to the enclosure.
- Step 3** Install the WiFi antenna.



## NOTICE

Ensure that the WiFi antenna is installed securely.

**Figure 4-20** Installing a WiFi antenna



----End

---

# 5 Electrical Connections

---

## Precautions



### **DANGER**

Before connecting cables, ensure that the DC switch on the SUN2000L and all the switches connecting to the SUN2000L are OFF. Otherwise, the high voltage of the SUN2000L may result in electric shocks.

---



### **WARNING**

- The equipment damage caused by incorrect cable connections is beyond the warranty scope.
  - Only certified electricians are allowed to connect cables.
  - Operation personnel must wear proper PPE when connecting cables.
- 

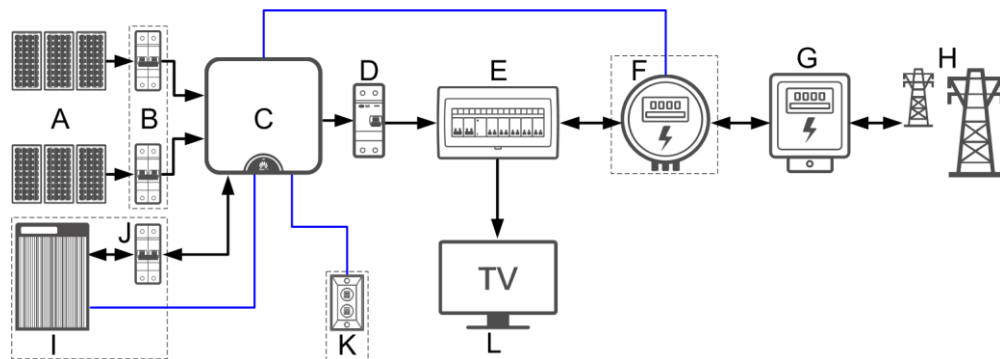


### **NOTE**

The cable colors shown in the electrical connection diagrams provided in this chapter are for reference only. Select cables in accordance with local cable specifications (green-and-yellow cables are only used for PE).

## 5.1 Preparing Cables

**Figure 5-1** Network diagram (dashed boxes indicate optional components)

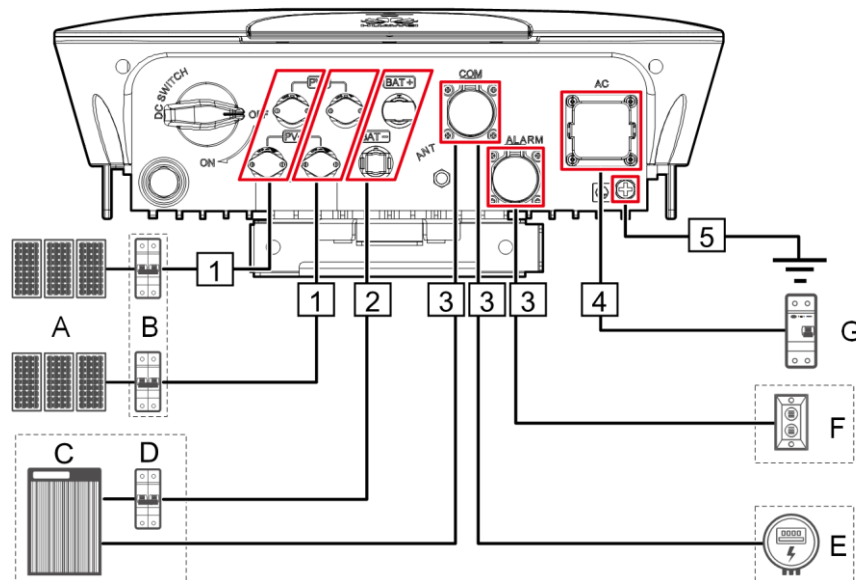


**NOTE**

— indicates a power cable, → indicates the power flow direction, and — indicates a signal cable.

- |                    |                             |                      |
|--------------------|-----------------------------|----------------------|
| (A) PV string      | (B) DC switch               | (C) SUN2000L         |
| (D) AC switch      | (E) Power distribution unit | (F) Energy meter     |
| (G) Power meter    | (H) Power grid              | (I) Battery          |
| (J) Battery switch | (K) Alarm beacon            | (L) Residential load |

**Figure 5-2** SUN2000L cable connections (dashed boxes indicate optional components)



**Table 5-1** Component description

No.	Component	Description	Source
A	PV string	<ul style="list-style-type: none"> <li>• A PV string is composed of the PV modules connected in series and works with an optimizer.</li> <li>• The SUN2000L supports the input from two PV strings.</li> </ul>	Prepared by the customer
B	DC switch	Recommended: a DC circuit breaker with a rated voltage greater than or equal to 600 V DC and a rated current of 20 A	Prepared by the customer
C	Battery	The batteries that can connect to the SUN2000L are LG-RESU (LG RESU7H and RESU10H).	Prepared by the customer
D	Battery switch	Recommended: a DC circuit breaker with a rated voltage greater than or equal to 600 V DC and a rated current of 20 A	Prepared by the customer
E	Energy meter	The energy meters that can connect to the SUN2000L are CHINT-DDSU666, CCS-WNC-3Y-400-MB, Gavazzi-EM112DINAV01XS1X, Gavazzi-EM340DINAV23XS1X and Gavazzi-EM111DINAV81XS1X.	Prepared by the customer
F	Alarm beacon	The rated voltage is 12 V and the power is less than or equal to 3 W.	Prepared by the customer
G	AC switch	Recommended: a single-phase AC circuit breaker with a rated voltage greater than or equal to 250 V AC and a rated current of <ul style="list-style-type: none"> <li>• 16 A (SUN2000L-2KTL)</li> <li>• 25 A (SUN2000L-3KTL and SUN2000L-3.68KTL)</li> <li>• 32 A (SUN2000L-4KTL, SUN2000L-4.6KTL, and SUN2000L-5KTL)</li> </ul>	Prepared by the customer





### NOTICE

- The SUN2000L is embedded with a residual current monitoring unit (RCMU). Only a single-phase circuit breaker or a similar AC load breaking device is required to function as the external AC switch (shown by G in [Figure 5-2](#)) to ensure that the SUN2000L can be safely disconnected from the power grid.
- If the external AC switch can perform earth leakage protection, the rated leakage action current should be greater than or equal to 100 mA.
- If multiple SUN2000Ls connect to the general residual current device (RCD) through their respective external AC switches, the rated leakage action current of the general RCD should be greater than or equal to the number of SUN2000Ls multiplied by 100 mA.
- A knife switch cannot be used as an AC switch.

**Table 5-2** Cable description

No.	Cable	Type	Conductor Cross-sectional Area Range	Outer Diameter	Source
1	DC input power cable	Standard PV cable in the industry (recommended model: PV1-F)	4–6 mm <sup>2</sup>	4.5–7.8 mm	Prepared by the customer
2	Battery cable	Standard PV cable in the industry (recommended model: PV1-F)	4–6 mm <sup>2</sup>	4.5–7.8 mm	Prepared by the customer
3	Signal cable	Four-core outdoor shielded twisted pair cable	0.25–1 mm <sup>2</sup>	4–11 mm	Prepared by the customer
4	AC output power cable	<ul style="list-style-type: none"> <li>• Not using the PE equipotential point at the AC output port: two-core (L and N) outdoor copper cable</li> <li>• Using the PE equipotential point at the AC output port: three-core (L, N, and PE) outdoor copper cable</li> </ul>	4–6 mm <sup>2</sup>	10–21 mm	Prepared by the customer
5	PE cable	Single-core outdoor copper cable with an M6 OT terminal	4–10 mm <sup>2</sup>	N/A	Prepared by the customer



### NOTICE

The PE point at the AC output port is used only as a PE equipotential point, and cannot substitute for the PE point on the enclosure.

## 5.2 Installing the PE Cable

### Context



#### DANGER

Do not connect the neutral wire to the enclosure as a PE cable. Otherwise, electric shocks could occur.

### Procedure

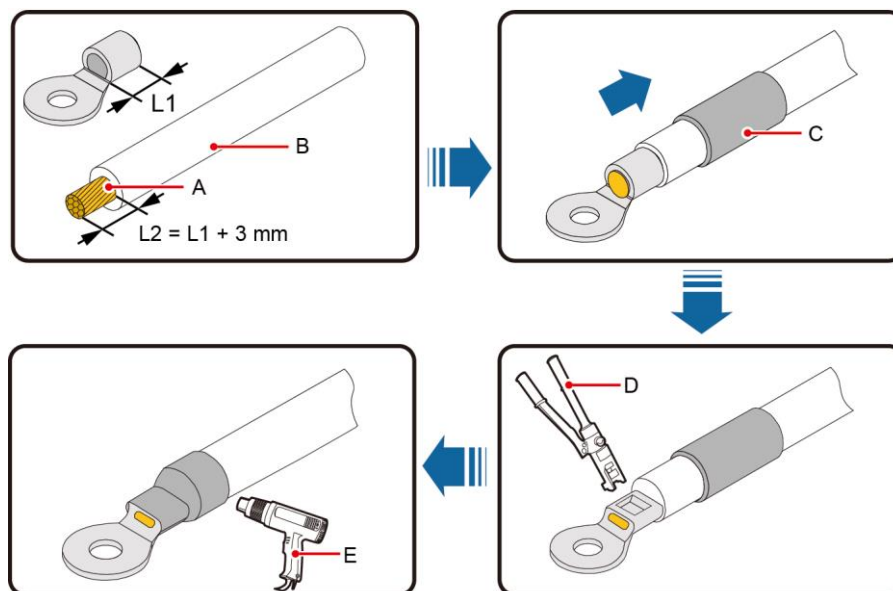
**Step 1** Crimp the OT terminal.



#### NOTICE

- Pay attention not to damage the core wire when stripping a cable.
- The cavity formed after the conductor crimp strip of the OT terminal is crimped must wrap the core wires completely. The core wires must contact the OT terminal closely.
- Wrap the wire crimping area with heat shrink tubing or PVC insulation tape. The following figure uses heat shrink tubing as an example.
- When using the heat gun, protect devices from being scorched.

**Figure 5-3** Crimping an OT terminal



IS05Z00001

(A) Core wire

(B) Insulation layer

(C) Heat shrink tubing

(D) Hydraulic pliers

(E) Heat gun

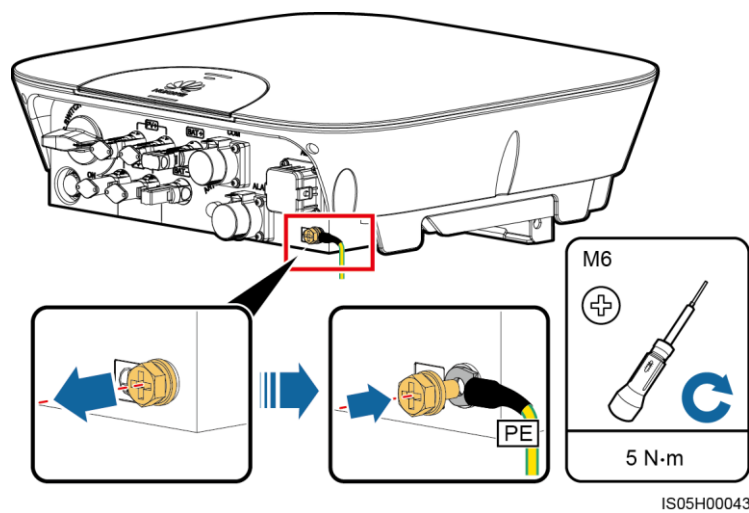
**Step 2** Connect the PE cable.



### NOTICE

Ensure that the PE cable is connected securely.

**Figure 5-4** Connecting a PE cable



### NOTE

- The PE point at the AC output port is used only as a PE equipotential point, and cannot substitute for the PE point on the enclosure.
- To enhance the corrosion resistance of a ground terminal, apply silica gel or paint around the terminal after connecting the PE cable.

----End

## 5.3 Installing the AC Output Power Cable

### Prerequisites

An AC switch must be installed on the AC side of the SUN2000L to ensure that the SUN2000L can be safely disconnected from the power grid.



## WARNING

Do not connect any load between the SUN2000L and the AC switch.

## Context

The SUN2000L can detect the grounding. This function is used to detect whether the SUN2000L is properly grounded before starting it, or to detect whether the PE cable is disconnected when the SUN2000L is working. This function is available only under limited conditions. To ensure the safe operation of the SUN2000L, properly ground the SUN2000L in strict accordance with the connection requirements for PE cables. For certain types of power grids, if an isolation transformer connects to the output side of the SUN2000L, you need to set **OFF due to abnormal grounding** to **Disable** (see [7.4.5.3 Feature Parameters](#) for details) after checking that the SUN2000L is properly grounded. Then the SUN2000L can start normally. If you are not sure whether the SUN2000L connects to such a power grid, confirm it with your supplier or Huawei technical support.



## NOTE

- According to IEC62109, to ensure the safe operation of the SUN2000L in the case of PE cable damage or disconnection, connect the SUN2000L PE cable according to the requirements described in [5.2 Installing the PE Cable](#) and ensure that the SUN2000L PE cable meets at least one of the following requirements before disabling the grounding detection function.

The SUN2000L PE cable is a copper cable with a cross-sectional area of at least 10 mm<sup>2</sup>.

Use two cables that have the same diameter as the AC output power cable to ground the PE terminal on the AC connector and the ground screw on the enclosure respectively (see [5.2 Installing the PE Cable](#) and [5.3 Installing the AC Output Power Cable](#) for details).

- Certain countries require an additional PE cable for the SUN2000L. In this case, use two cables that have the same diameter as the AC output power cable to ground the PE terminal on the AC connector and the ground screw on the enclosure respectively (see [5.2 Installing the PE Cable](#) and [5.3 Installing the AC Output Power Cable](#) for details).

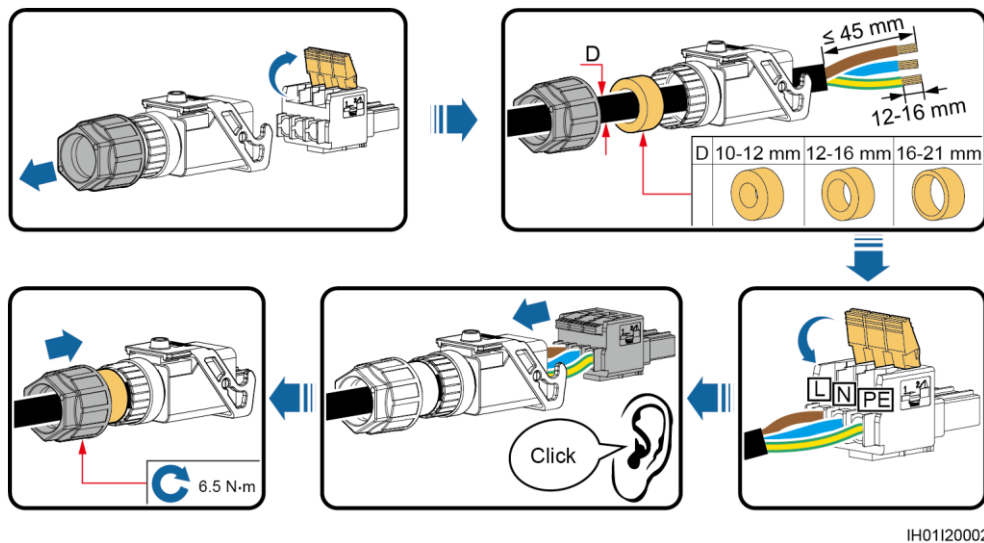
## Procedure

**Step 1** Connect the AC output power cable to the AC connector.

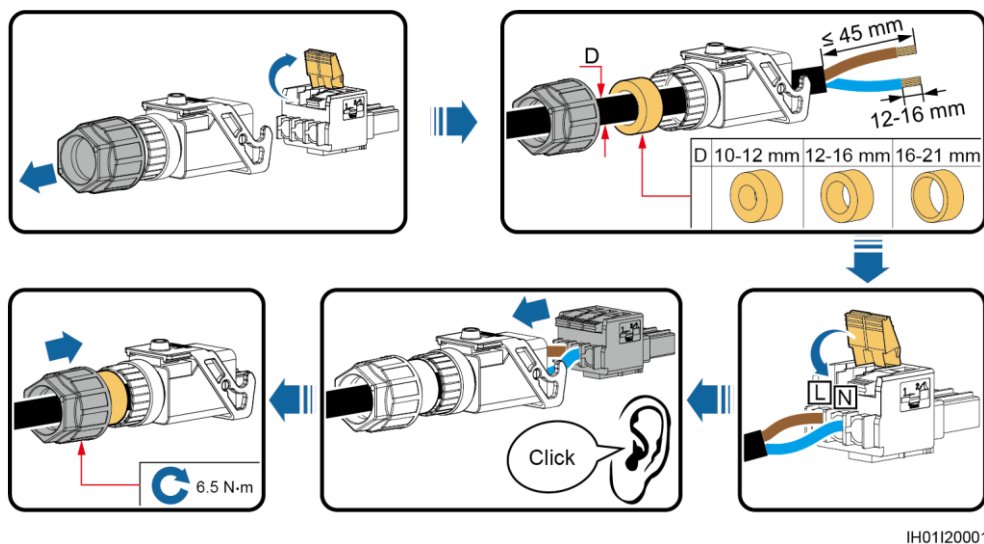
 **NOTICE**

- Ensure that the cable jacket is inside the connector.
- Ensure that the exposed core wire is totally inserted into the cable hole.
- Ensure that AC terminations provide firm and solid electrical connections. Failing to do so may cause SUN2000L malfunction and damage to its AC connectors.
- Ensure that the cable is not twisted.

**Figure 5-5** Assembling an AC connector (three-core wire)



**Figure 5-6** Assembling an AC connector (two-core wire)

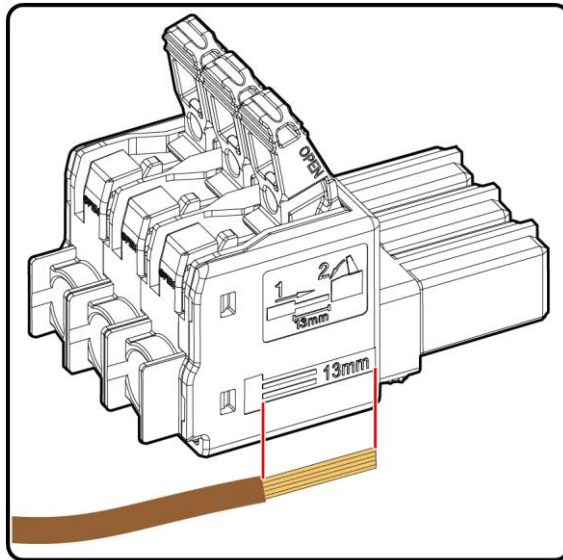




**NOTE**

- The cable colors shown in figures are for reference only. Select an appropriate cable according to the local standards.
- For the core wire installation method and stripped length, see the instructions on the side of the plug insert.

**Figure 5-7** Stripped length



IS05W00036

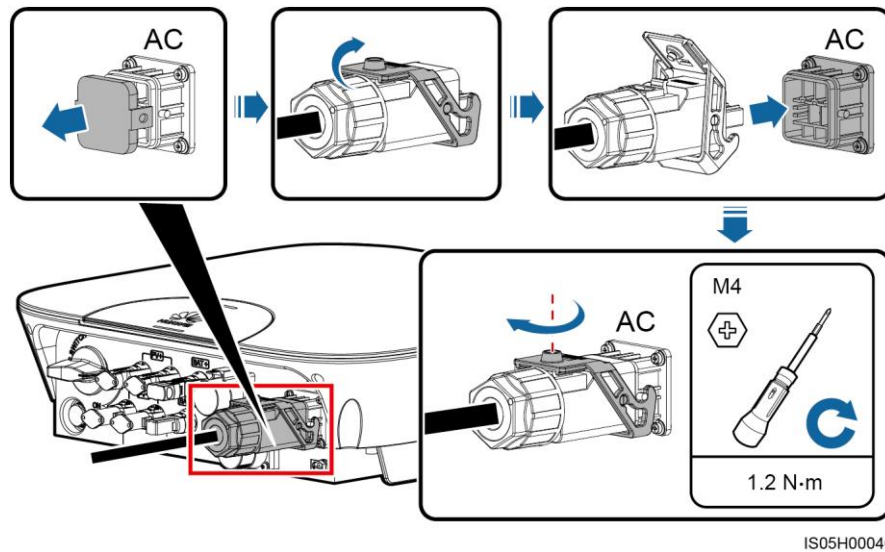
**Step 2** Connect the AC connector to the AC output port.



**NOTICE**

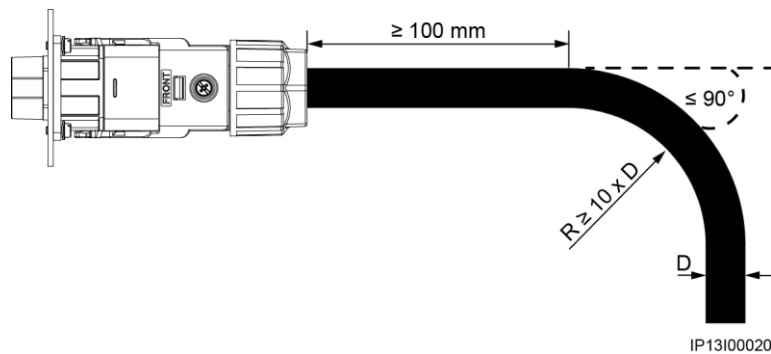
Ensure that the AC connector is connected securely.

**Figure 5-8** Securing an AC connector



**Step 3** Check the route of the AC output power cable.

**Figure 5-9** Cable route



----End

## Follow-up Procedure

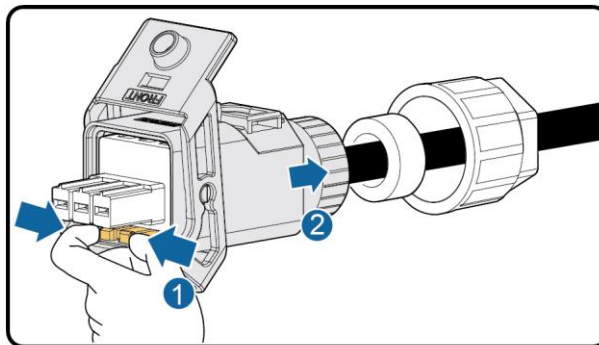


### WARNING

Before removing the AC connector, ensure that the DC switch at the bottom of the SUN2000L and all the switches connecting to the SUN2000L are OFF.

To remove the AC connector from the SUN2000L, perform the operations in reverse order.

**Figure 5-10** Removing a plug insert



IS05H00031

## 5.4 Installing the DC Input Power Cable

### Prerequisites



#### **DANGER**

- Before connecting the DC input power cable, ensure that the DC voltage is within the safe range (lower than 60 V DC) and that the DC switch on the SUN2000L is OFF. Failing to do so may result in electric shocks.
- When the SUN2000L is operating, it is not allowed to work on DC circuit, such as connecting or disconnecting a PV string or a PV module in a PV string. Failing to do so may cause electric shocks.
- If no PV string connects to the DC input terminals, do not remove the watertight cap from the DC input terminals. Otherwise, the SUN2000L will not comply with its Ingress Protection Rating.



#### **WARNING**

Ensure that the following conditions are met. Otherwise, the SUN2000L will be damaged, or even become a fire hazard.



- The open-circuit voltage of each PV string is always lower than or equal to 600 V DC.
- The positive and negative terminals of a PV string connect to corresponding positive and negative DC input terminals of the SUN2000L.
- If polarity of the DC input power cable is reversed and the DC switch is ON, do not turn off the DC switch immediately or unplug positive and negative connectors. Wait until the solar irradiance declines at night and the PV string current reduces to below 0.5 A, and then turn off the DC switch and remove the positive and negative connectors. Correct the string polarity before reconnecting the string to the SUN2000L.

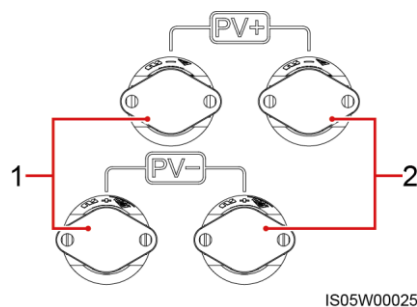


## NOTICE

- Since the output of the PV string connected to the SUN2000L cannot be grounded, ensure that the PV module output is well insulated to ground.
- During the installation of PV strings and SUN2000L, the positive or negative terminals of PV strings may be grounded if power cables are not properly installed or routed. In this case, an AC or DC short circuit may occur and damage the SUN2000L. This damage is not covered under any warranty.

## Context

Figure 5-11 DC input terminals



(1) The first set of DC input terminals

(2) The second set of DC input terminals

## Procedure

- Step 1** Assemble the black positive and negative connectors.



## CAUTION

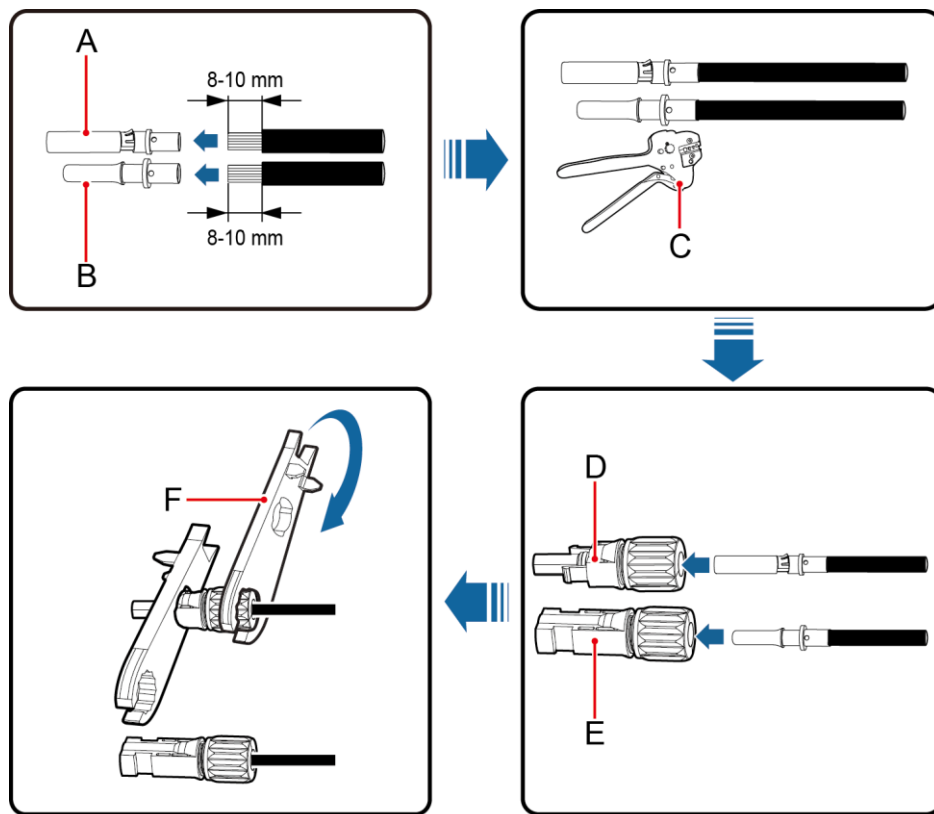
Use the positive and negative metal contacts and DC connectors supplied with the SUN2000L. Using incompatible positive and negative metal contacts and DC connectors may result in serious consequences. The caused device damage is not covered under any warranty.



### NOTICE

- Cables with high rigidity, such as armored cables, are not recommended as DC input power cables, because poor contact may be caused by the bending of the cables.
- Before assembling DC input connectors, label the cable polarities correctly to ensure correct cable connections.
- After crimping the positive and negative metal contacts, pull the DC input power cables back to check that they are connected securely.
- Insert the crimped metal contacts of the positive and negative power cables into the corresponding positive and negative connectors. Then pull back the DC input power cables to check that they are connected securely.

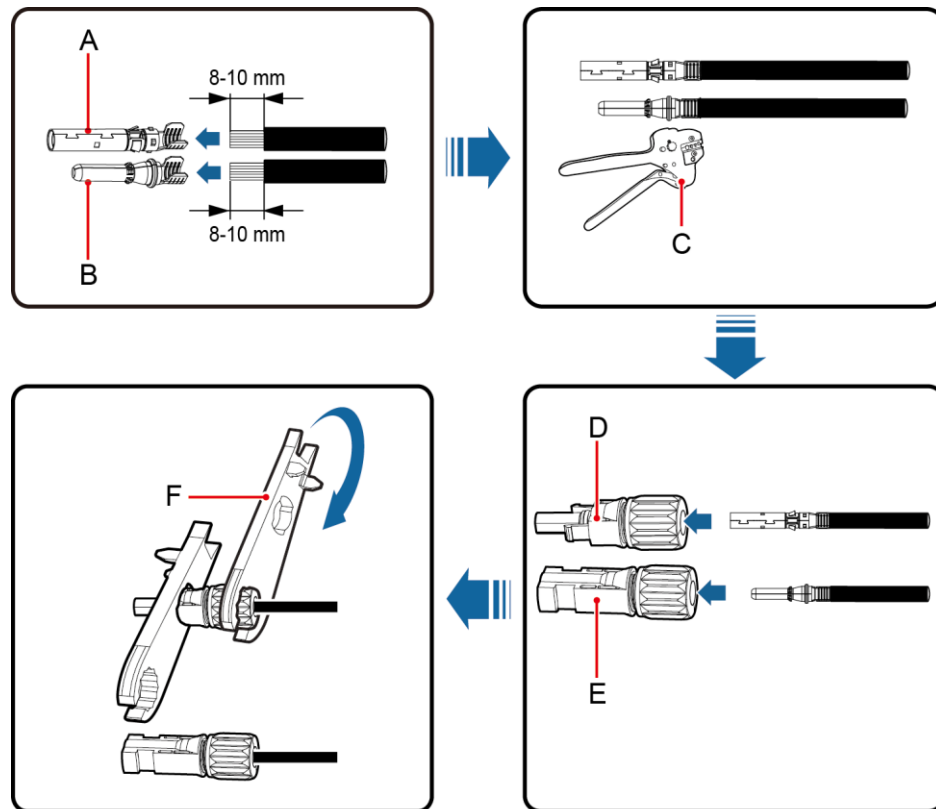
**Figure 5-12** Assembling DC connectors (using metal cold forming contacts)



IS03H00021

- (A) Positive metal contact    (B) Negative metal contact    (C) H4TC0001 crimping tool  
(D) Positive connector    (E) Negative connector    (F) H4TW0001 open-end wrench

**Figure 5-13** Assembling DC connectors (using metal stamping forming contacts)



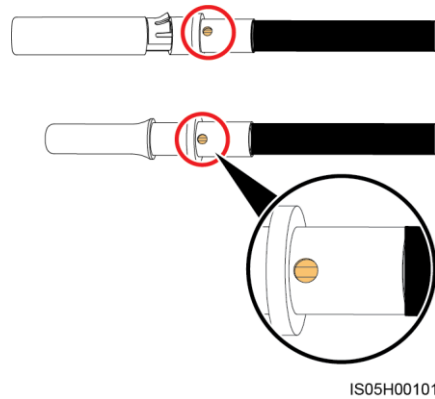
- (A) Positive metal contact    (B) Negative metal contact    (C) H4TC0002 crimping tool  
(D) Positive connector    (E) Negative connector    (F) H4TW0001 open-end wrench



**NOTICE**

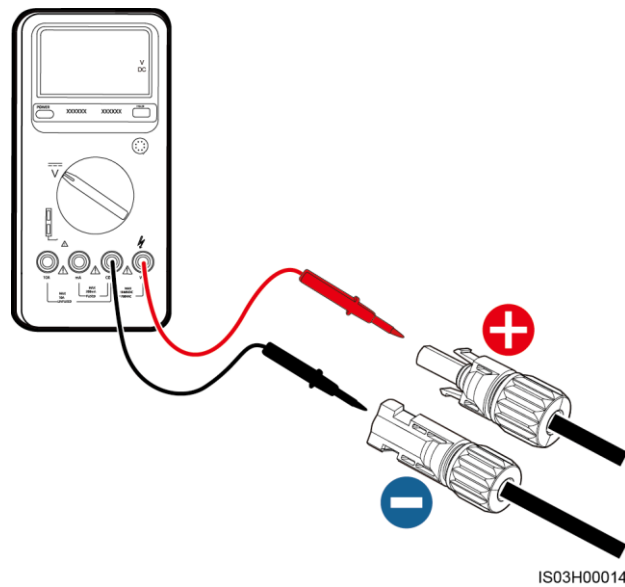
Ensure that the core wires can be seen through the hole on the terminal both before and after the positive and negative metal terminals are crimped.

**Figure 5-14** Observing core wires through the hole on the terminal



**Step 2** Ensure that the DC input voltage of each PV string is within the specified range of the SUN2000L using a multimeter and check that the polarities of DC input power cables are correct.

**Figure 5-15** Measuring the DC input voltage



**WARNING**

Before performing [Step 3](#), ensure that the DC switch is OFF.

**Step 3** Insert the positive and negative connectors into corresponding DC input terminals on the SUN2000L.

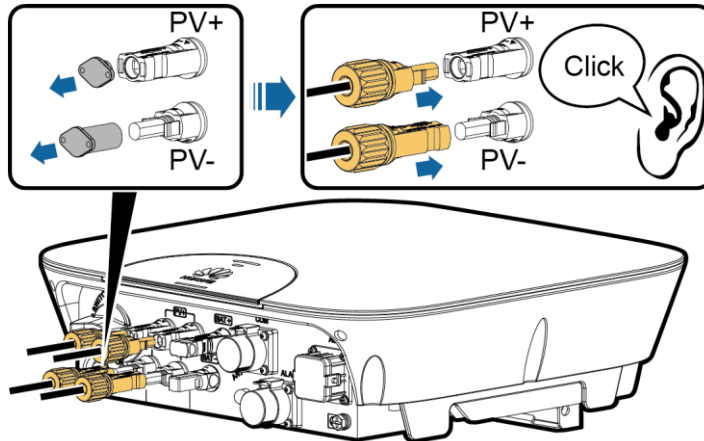
---

 **NOTICE**

After the positive and negative connectors snap into place, pull the DC input power cables back to check that they are connected securely.

---

**Figure 5-16** Connecting DC input power cables



IS05H00047

---

 **NOTICE**

If polarity of the DC input power cable is reversed and the DC switch is ON, do not turn off the DC switch immediately or unplug positive and negative connectors. The device may be damaged if you do not follow the instruction. This damage is not covered under any warranty. Wait until the solar irradiance declines at night and the PV string current reduces to below 0.5 A, and then turn off the DC switch and remove the positive and negative connectors. Correct the string polarity before reconnecting the string to the SUN2000L.

---

----End

## Follow-up Procedure

---

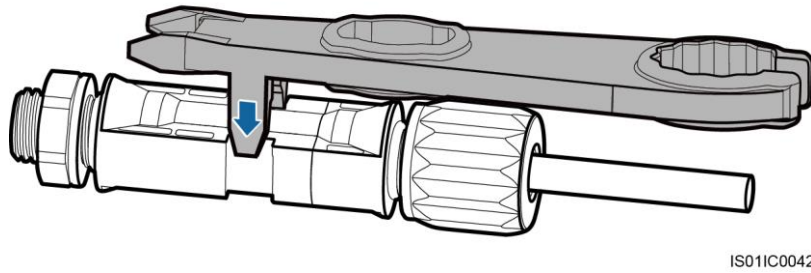
 **WARNING**

Before removing the positive and negative connectors, ensure that the DC switch is OFF.

---

To remove the positive and negative connectors from the SUN2000L, insert an open-end wrench into the notch and press the wrench with an appropriate force.

**Figure 5-17** Removing a DC connector



## 5.5 Installing Battery Cables

### Prerequisites



#### **DANGER**

- Battery short circuits may cause personal injury. The high transient current generated by a short circuit will release a surge of power and may even cause fire.
- Do not connect or disconnect battery cables when the SUN2000L is running. Failing to do so may cause electric shocks.
- Before connecting battery cables, ensure that the DC switch on the SUN2000L and all the switches connecting to the SUN2000L are OFF, and the SUN2000L has no residual electricity. Otherwise, the high voltage of the SUN2000L and battery may result in electric shocks.
- If no battery connects to the SUN2000L, do not remove the watertight cap from the battery terminal. Otherwise, the SUN2000L will not comply with its Ingress Protection Rating. If a battery connects to the SUN2000L, set aside the watertight cap. Reinstall the watertight cap immediately after removing the connector. The high voltage of the battery terminal may result in electric shocks.

A battery switch can be configured between the SUN2000L and the battery to ensure that the SUN2000L can be safely disconnected from the battery.



#### **WARNING**

Do not connect any load between the SUN2000L and the battery.

Ensure that the following conditions are met. Otherwise, the SUN2000L will be damaged, or even become a fire hazard.

The battery cables should be connected correctly. That is, the positive and negative terminals of the battery connect to the positive and negative battery terminals on the SUN2000L respectively.



### NOTICE

- During the installation of the SUN2000L and battery, the positive or negative terminal of the battery will be short-circuited to ground if power cables are not installed or routed as required. In this case, an AC or DC short circuit may occur and damage the SUN2000L. This damage is not covered under any warranty or service agreement.
  - The cables between the battery and the SUN2000L should be less than or equal to 10 meters, and within 5 meters is recommended.
- 

## Procedure

- Step 1** Assemble the blue positive and negative connectors by following the instructions in [5.4 Installing the DC Input Power Cable](#).
- 



### DANGER

- The battery voltage will result in serious injury. Use dedicated insulation tools to connect cables.
  - Ensure that cables are correctly connected between the battery terminal and the battery switch, and between the battery switch and the SUN2000L battery terminal.
- 



### NOTICE

Cables with high rigidity, such as armored cables, are not recommended, because poor contact may be caused by the bending of the cables.

---

- Step 2** Insert the positive and negative connectors into corresponding battery terminals on the SUN2000L.
- 

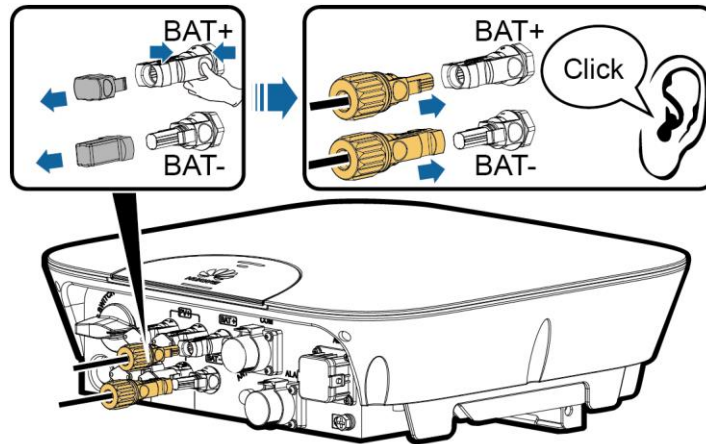


### NOTICE

After the positive and negative connectors snap into place, pull the battery cables back to check that they are secured.

---

**Figure 5-18** Installing battery cables



----End

## 5.6 Installing the Signal Cable

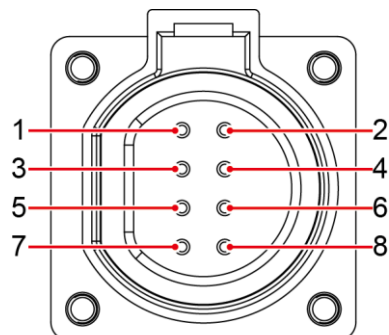
### Context



#### NOTICE

When laying out signal cables, separate them from power cables to avoid strong signal interference sources.

**Figure 5-19** Signal Cable Ports



IS05W00024

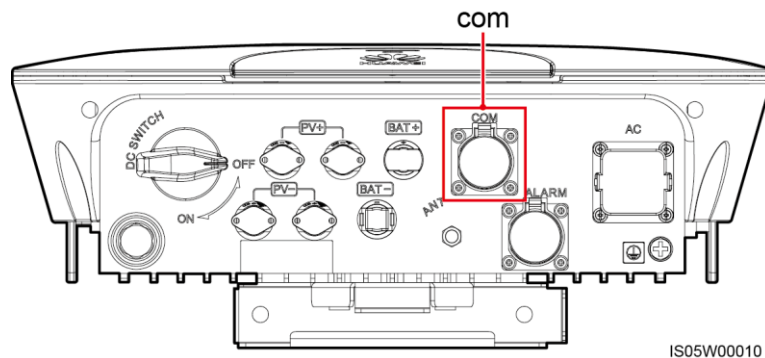


#### NOTE

Signal cable ports are classified into COM ports and ALARM ports.



**Figure 5-20** COM Ports



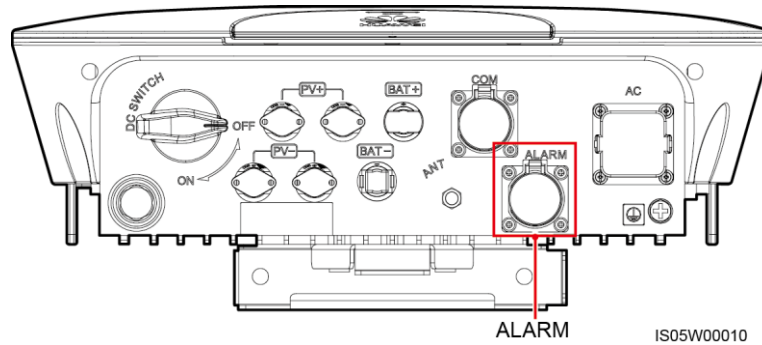
IS05W00010

The COM port provides two RS485 communications ports and one enable signal port to connect to energy meters, batteries, and so on.

**Table 5-3** COM port definitions

No.	Label	Definition	Description
1	485B1	RS485B, RS485 differential signal-	Reserved, can connect to the RS485 signal port on the energy meter.
2	485A1	RS485A, RS485 differential signal+	
3	485B2	RS485B, RS485 differential signal-	Reserved, can connect to the RS485 signal port and enable signal port on a battery.
4	485A2	RS485A, RS485 differential signal+	
5	EN-	Enable signal-	
6	EN+	Enable signal+	
7	N/A	N/A	N/A
8	PE	Shielding ground	Connects to the shield layer of the cable.

**Figure 5-21** ALARM Ports



The ALARM port provides an alarm signal port to connect to an alarm beacon, which reminds the user to handle the **Low Insulation Resistance, Abnormal Residual Current, or Faulty Residual Current Sensor** alarm. The ALARM port reserves an RS485/12 V signal port.



**NOTICE**

- The alarm beacon should be installed within 2 meters away from the SUN2000L.
- The **Faulty Residual Current Sensor** alarm is the Abnormal Device alarm with a cause ID of 5.

**Table 5-4** ALARM port definitions

No.	Label	Definition	Description
1	ALARM-	Alarm signal-	Reserved, can connect to the power port on an alarm beacon
2	ALARM+	Alarm signal+	
3	485B3	RS485B, RS485 differential signal-	Reserved RS485/12 V signal port, output power of the 12 V power supply $\leq 3$ W
4	485A3	RS485A, RS485 differential signal+	
5	12 V-	Negative of the 12 V power supply	
6	12 V+	Positive of the 12 V power supply	
7	N/A	N/A	N/A
8	PE	Shielding ground	Connects to the shield layer of the cable.

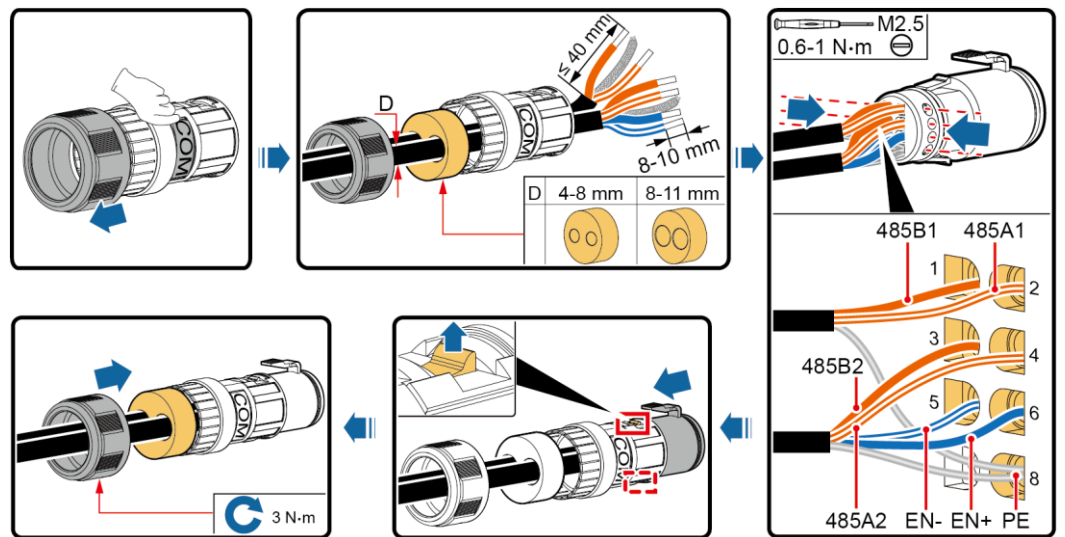
**Procedure**

**Step 1** Connect signal cables to appropriate signal connectors.

 **NOTICE**

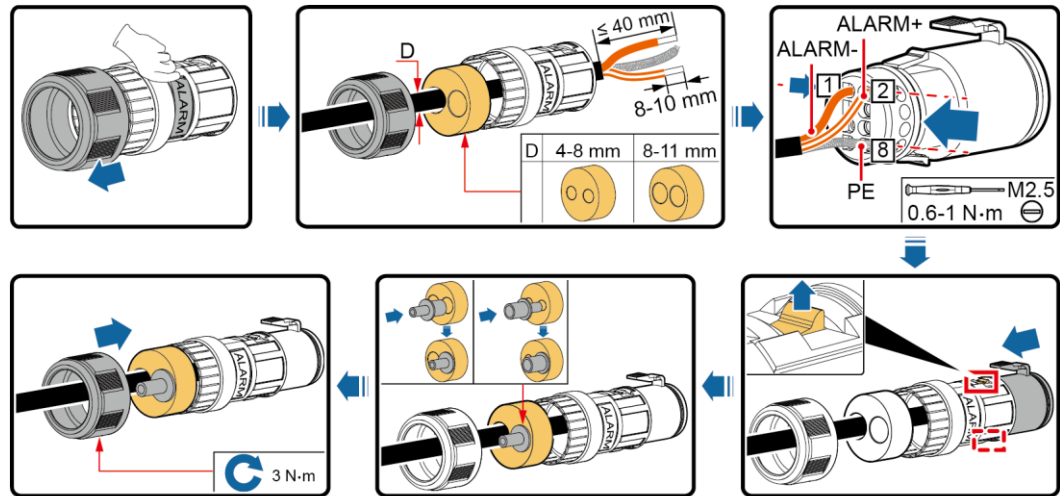
- The protection layer of the cable is in the connector. Surplus core wires are cut off from the protection layer.
- Ensure that the exposed core wire is totally inserted into the cable hole.
- Ensure that the signal cables are connected securely.
- Ensure that the cable is not twisted.
- If a connector needs to connect to only one signal cable, block the unused cable hole on the seal using a waterproofing bolt and tighten the sealing nut.
- If a connector needs to connect to two signal cables, ensure that the cables have the same outer diameter.

**Figure 5-22** Assembling a signal connector (COM port)



IH01140002

**Figure 5-23** Assembling a signal connector (ALARM port)



IH01140009

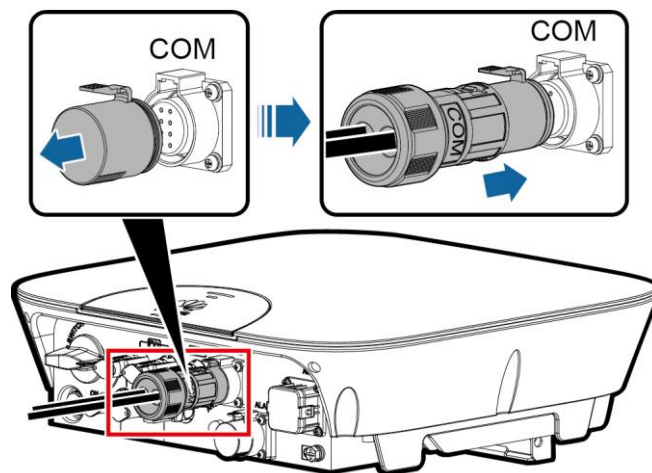
**Step 2** Connect the signal connector to the corresponding port.



**NOTICE**

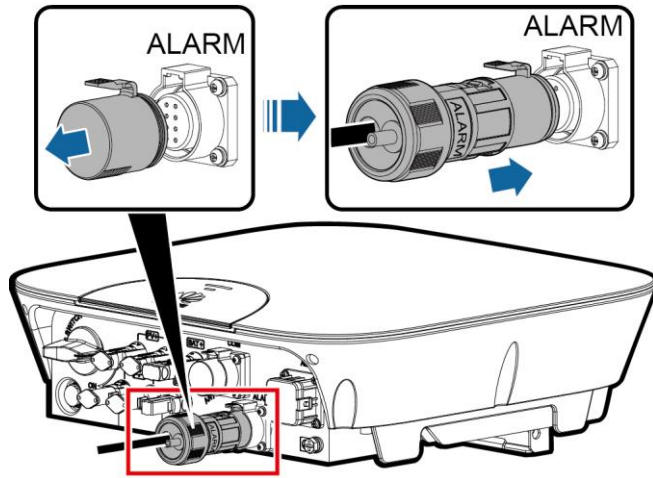
- Do not confuse the connector to the COM port with that of ALARM port.
- Ensure that the signal connector is connected securely.

**Figure 5-24** Securing a connector (COM port)



IS05H00044

**Figure 5-25** Securing a connector (ALARM port)



IS05H00099

----End

# 6 System Commissioning

## 6.1 Checking Before Power-On

**Table 6-1** Installation checklist

No.	Check Item	Acceptance Criteria
1	SUN2000L installation	The SUN2000L is installed correctly, securely, and reliably.
2	WiFi antenna installation	The WiFi antenna is installed correctly, securely, and reliably.
3	Cable layout	Cables are routed properly as required by the customer.
4	Cable tie	Cable ties are secured evenly and no burr exists.
5	Grounding	The ground cable is connected correctly, securely, and reliably.
6	Switch status	The DC switch and all the switches connecting to the SUN2000L are OFF.
7	Cable connections	The AC output power cable, DC input power cable, battery cable, and signal cable are connected correctly, securely, and reliably.
8	Unused terminals and ports	Unused terminals and ports are blocked by watertight caps.
9	Installation environment	The installation space is proper, and the installation environment is clean and tidy, without foreign matter.

## 6.2 Powering On the System

### Prerequisites

Before turning on the AC switch between the SUN2000L and the power grid, check that the AC voltage on the power grid side of the AC switch is within the specified range.



### NOTICE

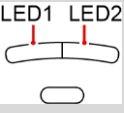

- If the DC is on and the AC is off, the SUN2000L reports a **Grid Failure** alarm. The SUN2000L starts normally only after the fault is rectified.
  - If the AC is on and the battery is off, the SUN2000L reports a **Battery Abnormal** alarm.
  - If the SUN2000L is connected to the battery, after turning on the AC switch:
    - If the DC switch is turned on within 1 minute, the SUN2000L will run properly in grid-tied mode.
    - If the DC switch is not turned on within 1 minute, the SUN2000L will enter the nighttime grid-tied mode. Then, after the DC switch is turned on, the SUN2000L will shut down and then restart to operate in grid-tied mode.
- 

### Procedure

- Step 1** If a battery connects to the battery port, turn on the battery Auxiliary Power ON/OFF switch, and then turn on the battery Circuit Breaker switch.
- Step 2** Turn on the AC switch between the SUN2000L and the power grid.
- Step 3** Turn on the DC switch between the PV string and the SUN2000L if there is any.
- Step 4** Turn on the DC switch at the bottom of the SUN2000L.
- Step 5** Set the SUN2000L parameters on the app. For details, see [7 Operations on the Local FusionHome App](#).
- Step 6** (Optional) Measure the temperatures at DC terminals and battery terminals using a point-test thermometer.

Under normal operation conditions of the SUN2000L, the temperature rise at DC terminals should remain below 30 °C at all time.
- Step 7** Observe the LEDs to check the SUN2000L operating status.

**Table 6-2** LED description

Type	Status		Meaning
<b>Running indication</b> 	<b>LED 1</b>	<b>LED 2</b>	N/A
	Steady green	Steady green	The SUN2000L is exporting power to the power grid.
	Blinking green at long intervals (on for 1s and then off for 1s)	Off	The DC is on and the AC is off.
	Off	Blinking green at long intervals (on for 1s and then off for 1s)	The DC is off and the AC is on.
	Blinking green at long intervals (on for 1s and then off for 1s)	Blinking green at long intervals (on for 1s and then off for 1s)	The DC is on, the AC is on, and the SUN2000L is not exporting power to the power grid.
	Off	Off	Both the DC and AC are off, or the SUN2000L is in Low Power Consumption mode. Low Power Consumption mode means that the monitoring system of the SUN2000L is hibernating.
	Steady red	Steady red	The SUN2000L is faulty.
<b>Communication indication</b> 	<b>LED 3</b>		N/A
	Blinking green at short intervals (on for 0.2s and then off for 0.2s)		Communicating (Communicating means that the communication with the upper-level management unit is in progress. However, if a mobile phone accesses the SUN2000L, the LED indicates the "mobile phone access status: blinking green at long intervals" first.)
	Blinking green at long intervals (on for 1s and then off for 1s)		The mobile phone is connected to the SUN2000L.
Off		No communication	

----End



## 6.3 Powering Off the System

### Context



#### **WARNING**

- After the SUN2000L is powered off, the remaining electricity and heat may still cause electric shocks and body burns. Therefore, put on protective gloves and operate the SUN2000L 5 minutes after the power-off.
  - If the SUN2000L is connected to the battery, ensure that a shutdown command is sent from the app. Power off the system after the SUN2000L has shut down. If no shutdown command is sent from the app, the SUN2000L will shut down after the power grid is powered off. Then, the SUN2000L will wait for 1 minute and restart (not grid-tied) to charge the battery, which poses the risk of turning off the DC switch with power.
- 

### Procedure

- Step 1** Send a shutdown command from the app. Perform operations by referring to [7.4.3.5 Starting or Shutting Down the SUN2000L](#) if you log in as **installer**; perform operations by referring to [7.5.6 Settings](#) if you log in as **user**.
- Step 2** Turn off the AC switch between the SUN2000L and the power grid.
- Step 3** Turn off the DC switch at the bottom of the SUN2000L.
- Step 4** Turn off the DC switch between the PV string and the SUN2000L if there is any.
- Step 5** If a battery connects to the battery port, turn off the battery switch.

----End

# 7 Operations on the Local FusionHome App

## 7.1 App Overview

### Function

The local FusionHome app (app for short) is a mobile phone app that locally communicates with the SUN2000L over WiFi to allow for querying alarms, configuring parameters, performing routine maintenance, and commissioning.

### Connection Methods

After the DC or AC side of the SUN2000L is energized, the app can connect to the SUN2000L in either of the following ways:

- **Method 1:** The mobile phone connects to the SUN2000L directly.

**Figure 7-1** Mobile phone connecting to the SUN2000L directly



- **Method 2:** The mobile phone connects to the SUN2000L over a router. Do not use this method for the first login and ensure that the SUN2000L is connected to the router.

**Figure 7-2** Mobile phone connecting to the SUN2000L over a router





## NOTICE

- Mobile phone operating system: Android 4.4 or later, iOS 8.0 or later.
- Recommended brands: Huawei, Samsung, and iPhone
- The mobile phone supports the access to the Internet over a web browser.
- The mobile phone supports WiFi.
- The router supports WiFi (IEEE 802.11 b/g/n, 2.4 GHz) and the WiFi signal reaches the SUN2000L.

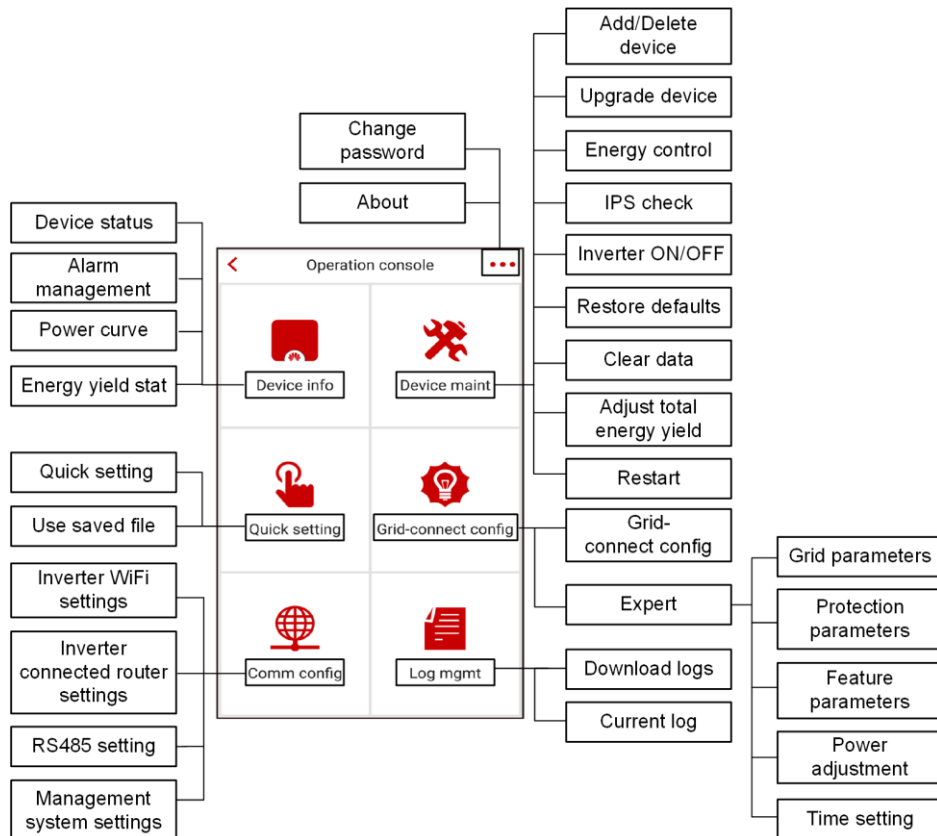
## Disclaimer

The app screen snapshots provided in this document correspond to FusionHome 2.1.11.201. The figures are for reference only.

## User Operation Permissions

The app users are classified into the installer and user.

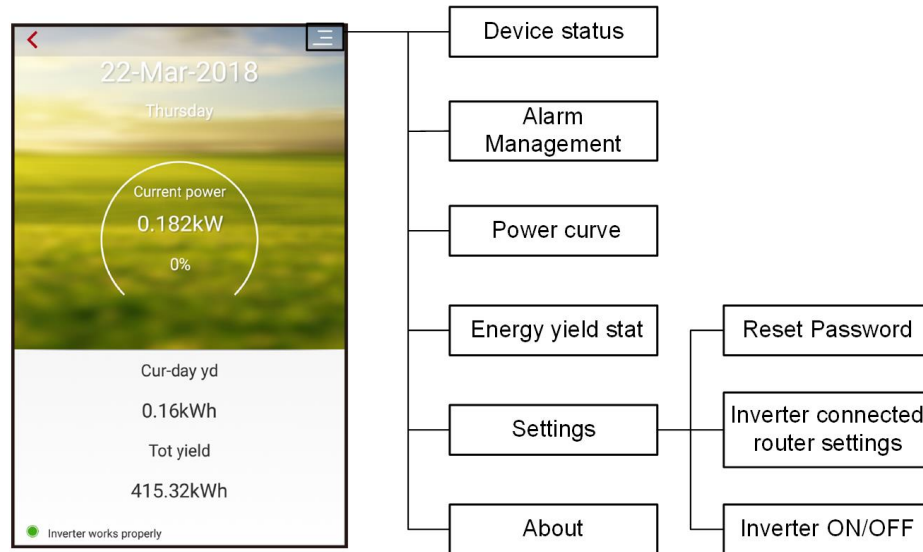
**Figure 7-3** Operation permissions of the installer



### NOTE

The **IPS check** function is available only for the Italy CEI0-21 grid code.

Figure 7-4 Operation permissions of the user



## 7.2 Downloading and Installing the App

Search for **FusionHome** from the following app stores, download the installation package, and install the FusionHome app by following the instructions.

- Google Play (Android)
- Huawei App Store (Android)
- App Store (iOS)

After the app is installed, the **FusionHome** icon is displayed on the home screen.



## 7.3 Connecting to the SUN2000L WiFi Network

### Prerequisites

- The DC or AC side of the SUN2000L has been energized.
- The WiFi function is enabled on the mobile phone.
- When connecting the SUN2000L to the app directly, keep the mobile phone within 5 meters of the SUN2000L with no barrier in between to ensure the communication quality between them.

- When connecting the SUN2000L to the app over a router, ensure that the mobile phone and SUN2000L are in the WiFi coverage of the router and the SUN2000L is connected to the router.

---

## NOTICE

The way of connecting the SUN2000L to the router is as follows:

- The installer taps **Quick setting** (see [7.4.4 Quick Setting](#) for details) or **Comm config** (see [7.4.6 Comm Config](#) for details).
- The user taps **Set** (see [7.5.6 Settings](#) for details).

---

## NOTE

- If the WiFi signal is weak, you will be prompted to try again multiple times. Follow the instructions.
- To exit the app, tap **Exit** on the **Inverter list** screen.

## Procedure on the Android System

The app allows for connecting to the SUN2000L in the following two ways. Select either way based on site requirements. After the connection succeeds, the **Inverter list** screen is displayed. If you fail to connect to the SUN2000L or router WiFi network on the app, try again from the phone system. To connect to the router over WiFi from the mobile phone system, ensure that you have logged out of the app.

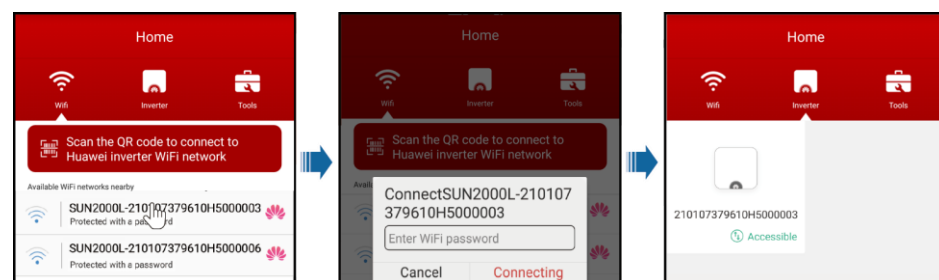
- **Method 1:** The mobile phone connects to the SUN2000L directly.

Run the app, tap the WiFi name corresponding to the SUN2000L, and enter the WiFi password to connect to the WiFi network. Use the initial password **Changeme** upon first login. To ensure account security, change the password immediately after login.

## NOTE

The name of the connected SUN2000L WiFi network is represented by **SUN2000L-its serial number (SN)**. The SN is available on the label attached to the side of the SUN2000L.

**Figure 7-5** Mobile phone connecting to the SUN2000L directly



## NOTE

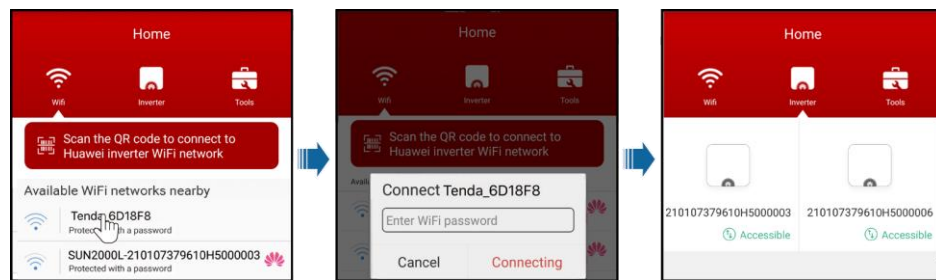
If you log in for the first time and the initial SUN2000L WiFi password is not changed, you can scan the WiFi login QR code on the side of the SUN2000L to connect to the SUN2000L WiFi network.

**Figure 7-6** Scanning the QR code to connect the mobile phone to the SUN2000L directly



- **Method 2:** The mobile phone connects to the SUN2000L over a router. Do not use this method for the first login and ensure that the SUN2000L is connected to the router. Run the app. If the SUN2000L WiFi network has connected to the router, tap the WiFi name corresponding to the router for connection. After the connection succeeds, the **Inverter list** screen displays all the Huawei SUN2000Ls that are connected to the router.

**Figure 7-7** Mobile phone connecting to the SUN2000L over a router



**NOTE**

If there is only one SUN2000L on the **Inverter list** screen, enter the WiFi password to go to the identity authentication screen.

----End

## Procedure on the iOS System

The app allows for connecting to the SUN2000L in the following two ways. Select either way based on site requirements. After the connection succeeds, the **Inverter list** screen is displayed.

- **Method 1:** The mobile phone connects to the SUN2000L directly.
  - a. Choose **Settings** > **WLAN** on your mobile phone and tap the WiFi name corresponding to the SUN2000L.

**NOTE**

The name of the connected SUN2000L WiFi network is represented by **SUN2000L-its serial number (SN)**. The SN is available on the label attached to the side of the SUN2000L.

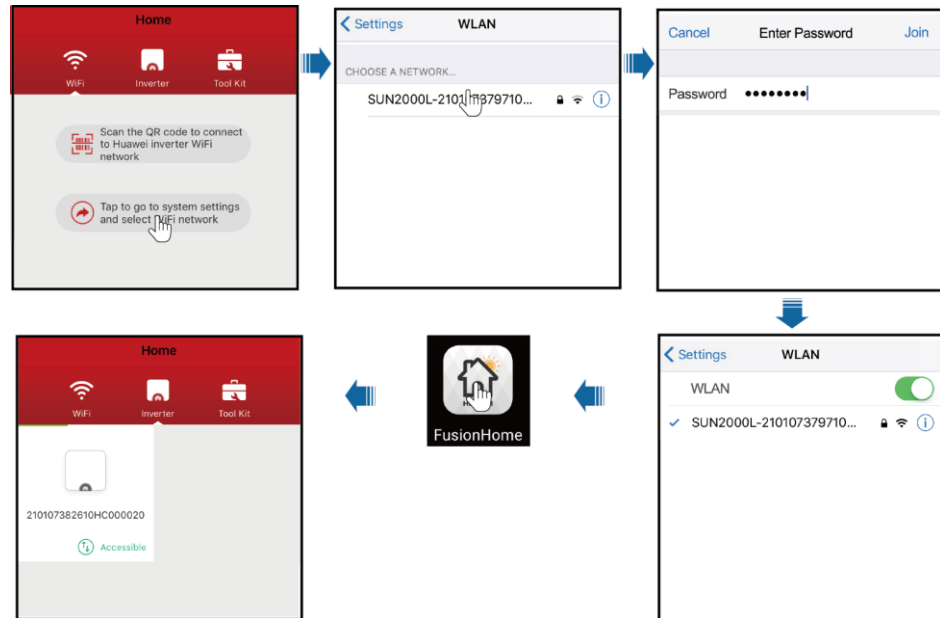
- b. Enter the SUN2000L WiFi password for connection. Use the initial password **Changeme** upon first login. To ensure account security, change the password immediately after login.

 **NOTE**

If you log in for the first time and the initial SUN2000L WiFi password is not changed, you can run the app, tap **Scan**, and scan the WiFi login QR code on the side of the SUN2000L to obtain the WiFi login password.

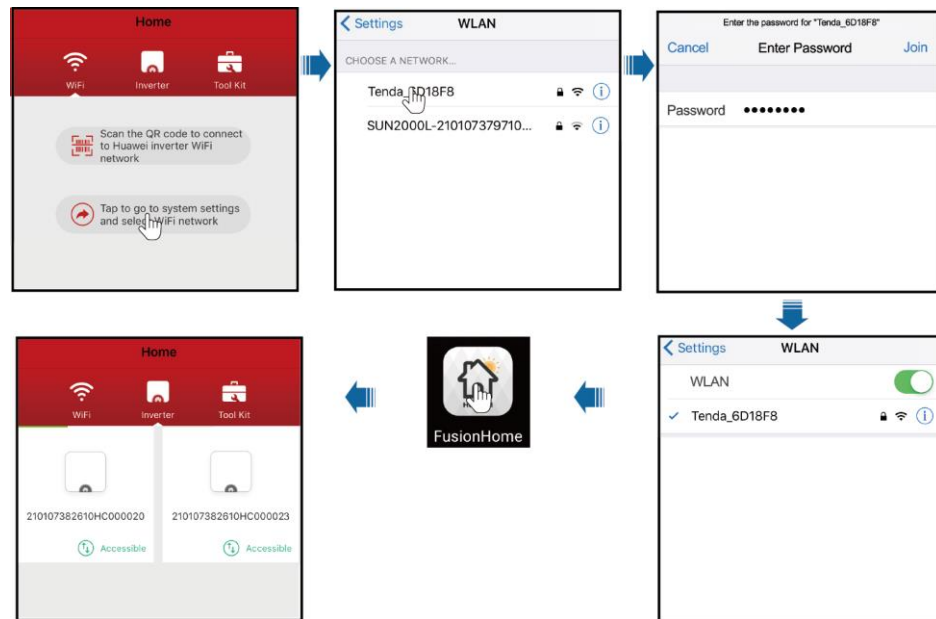
- c. Run the app. After the connection succeeds, the **Inverter list** screen is displayed.

**Figure 7-8** Mobile phone connecting to the SUN2000L directly



- **Method 2:** The mobile phone connects to the SUN2000L over a router. Do not use this method for the first login and ensure that the SUN2000L is connected to the router.
  - a. If the SUN2000L WiFi network is connected to the router, Choose **Settings** > **WLAN** on the mobile phone and tap the WiFi name corresponding to the router.
  - b. Enter the router WiFi password for connection.
  - c. Run the app. The **Inverter list** screen displays all the Huawei SUN2000Ls that are connected to the router.

**Figure 7-9** Mobile phone connecting to the SUN2000L over a router



----End



## NOTICE

The following text describes the operations on Android screens. The operations on iOS screens are the same as those on Android screens, except that the screens are somewhat different. The actual screens prevail.

## 7.4 App Operations by the Installer

### 7.4.1 Logging In to the App

#### Prerequisites

The corresponding SUN2000L is displayed on the **Inverter list** screen.

#### Procedure

**Step 1** On the **Inverter list** screen, choose **installer**, and enter the login password.

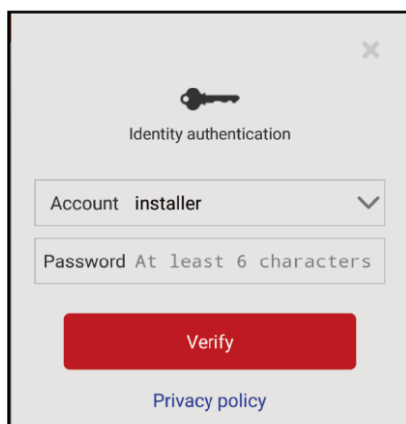
#### NOTE

- The name of the connected SUN2000L is represented by its serial number (SN), which is available on the SN label attached to the side of the SUN2000L.
- The login password is the same as that for the SUN2000L connected to the app and is used only when the SUN2000L connects to the app.
- The initial password is **0000a**. Use the initial password upon first login. To ensure account security, change the password immediately after login.



- If you enter wrong passwords for five consecutive times and the interval between two consecutive passwords is within 2 minutes, your account will be locked out for 5 minutes.

**Figure 7-10** Identity authentication



**Step 2** If you log in successfully, the **Quick setting** or **Operation console** screen is displayed.

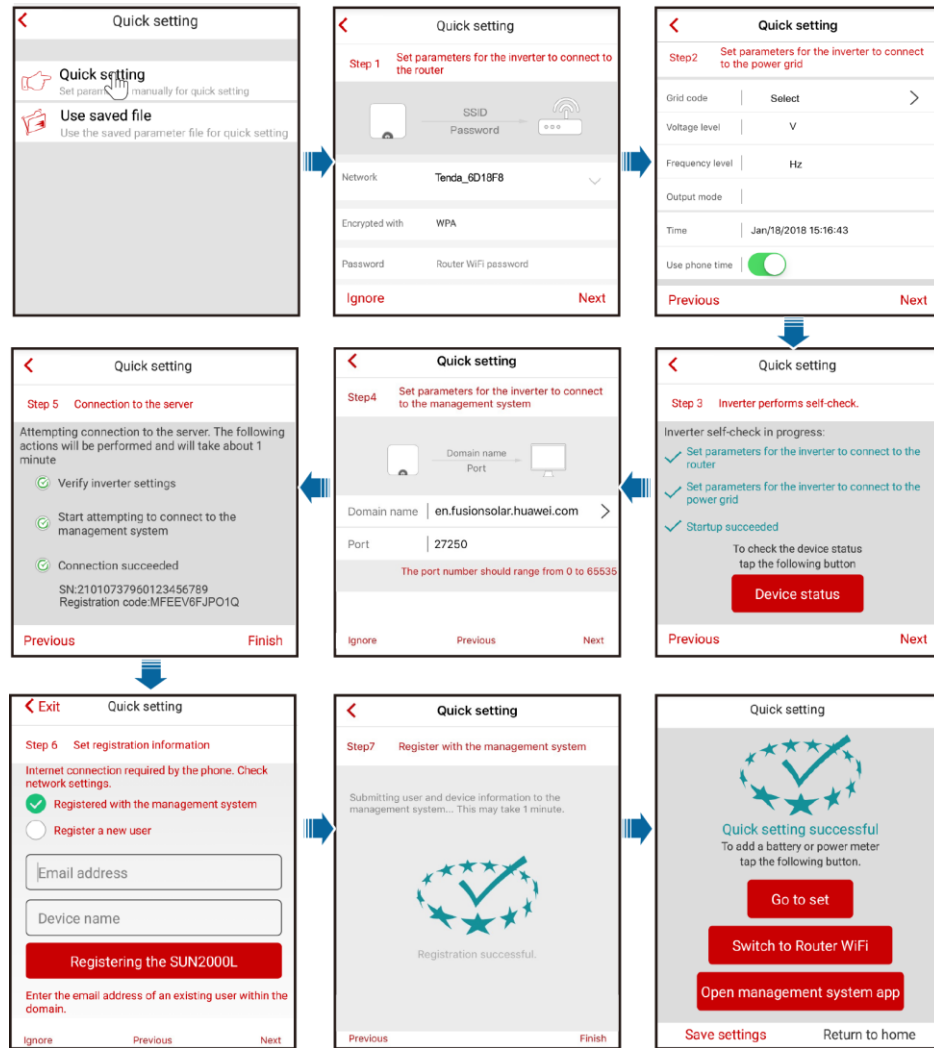
 **NOTE**

- The **Quick setting** screen is displayed only when the SUN2000L connects to the app for the first time or the factory defaults of the SUN2000L are restored.
- If you do not follow the deployment wizard, the **Quick setting** screen is still displayed when you log in next time.
- To exit the deployment, press the **Back** button on the mobile phone or tap **Exit** on the screen. To enter the **Quick setting** screen again, choose **Quick setting** from the **Operation console** screen.

The **Quick setting** screen provides two deployment modes. Select either of them based on site requirements.

- **Method 1:** quick setting

Figure 7-11 Quick setting



**NOTE**

The app allows for two methods to register with the management system:

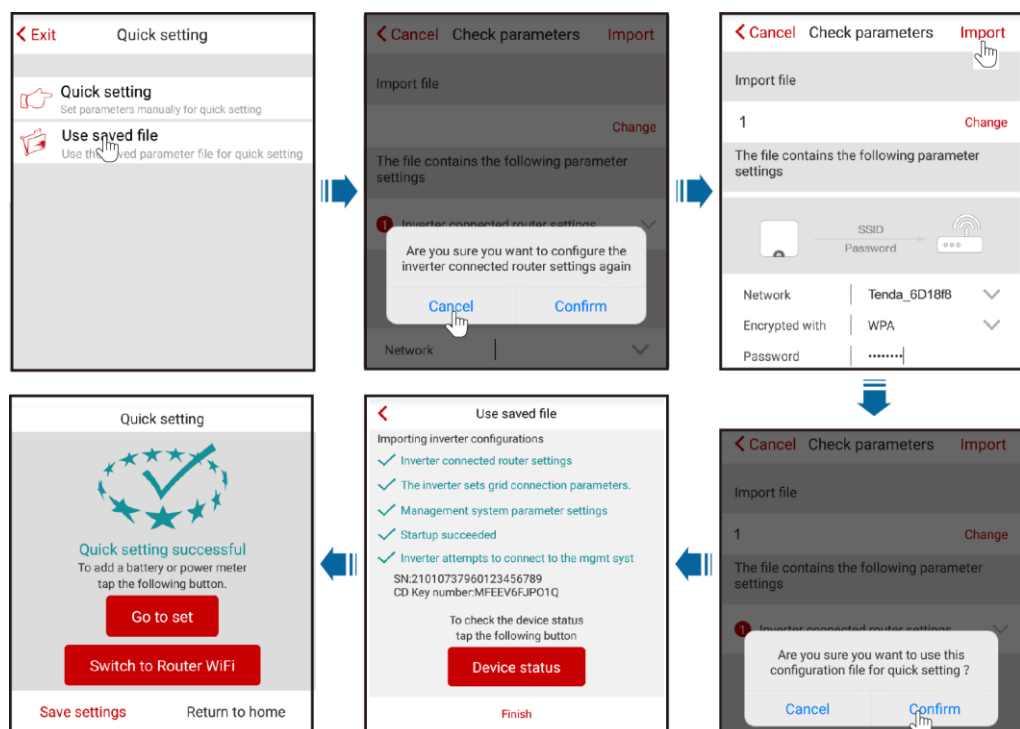
- The domain name can be selected by the right button in step 4.
- If you have registered in step 6, enter the email address and device name, and click **Next** or **Registering the SUN2000L**.
- If you have not registered in step 6, tap **Register a new user** to enter information for registration.
- Before tapping **Next** or **Registering the SUN2000L**, ensure that the mobile phone is connected to the Internet.

## NOTICE

- Set the grid code that applies to the country or region where the PV plant is located and the SUN2000L model.
  - If there is no need to connect to the router or management system, skip relevant steps.
  - After the management system is successfully connected, the SUN2000L will report the SN and installer registration code. If the connection fails, another connection attempt will start after 10 seconds. The installer registration code is generated by the SUN2000L automatically and is used for the installer to register with the management system and manage the inverter.
  - For the operations about how to add devices, see [7.4.3.1 Adding/Deleting Devices](#).
  - After quick setting is complete, tap **Switch to Router WiFi** to switch to the **Available WiFi networks nearby** screen and tap the corresponding router WiFi connection to switch to the router WiFi network.
  - To connect to the router WiFi network from the mobile phone system after router parameters are successfully set, you need to log out of the app and log in again.
  - After following all the instructions on the **Quick setting** screen, tap **Save settings** to store the configurations or tap **Return to home** to return to the **Operation console** screen.
- 
- **Method 2:** use the saved file

Before choosing **Use saved file** for quick setting, ensure that the corresponding configuration file is saved on your mobile phone. To generate a configuration file, tap **Save settings** on the **Quick setting** screen.

**Figure 7-12** Performing quick setting using a saved file

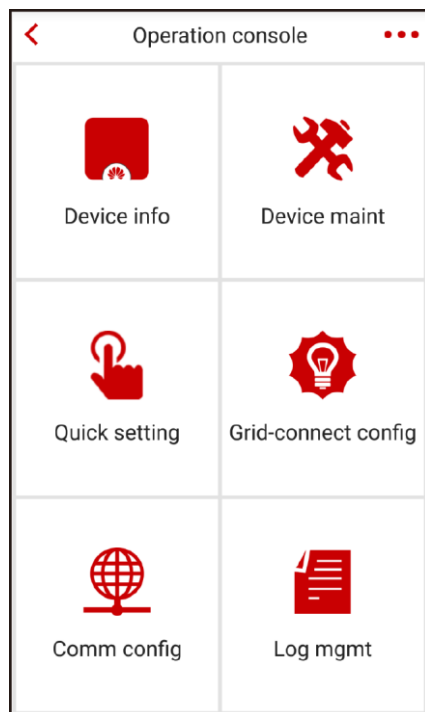




**NOTE**

- To change the configuration file to be imported, tap **Change**.
- In the dialog box with **Are you sure you want to configure the inverter connected router settings again**, if you tap **Confirm**, the router configurations saved before will be cleared. If you tap **Cancel**, you only have to enter the saved router password.
- After quick setting is complete, tap **Switch to Router WiFi** to switch to the **Available WiFi networks nearby** screen and tap the corresponding router WiFi connection to switch to the router WiFi network.
- To connect to the router WiFi network from the mobile phone system after router parameters are successfully set, you need to log out of the app and log in again.
- After the management system is successfully connected, the SUN2000L will report the SN and installer registration code. If the connection fails, another connection attempt will start after 10 seconds. The installer registration code is generated by the SUN2000L automatically and is used for the installer to register with the management system and manage the inverter.

**Figure 7-13** Operation console



----End

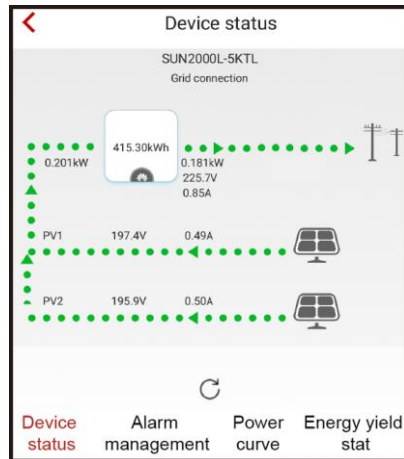
## 7.4.2 Querying the SUN2000L Information

To query the SUN2000L information, choose **Device info** from the **Operation console** screen.

### Querying the Device Status

You can query the status of each device.

Figure 7-14 Querying the device status



## Alarm Management

You can query active and historical alarms.



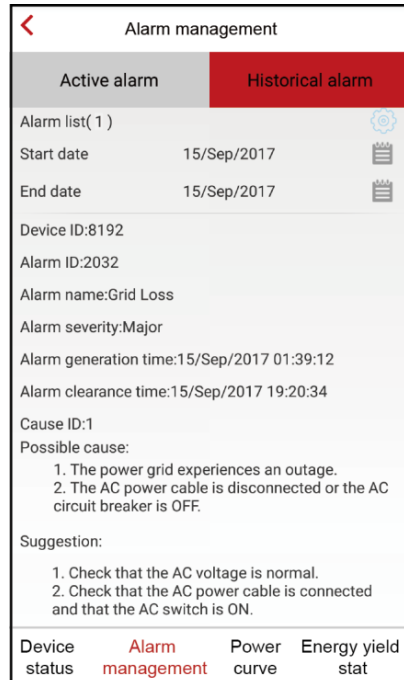
To set the sorting mode for active alarms or historical alarms, tap . To query the historical alarms within a certain time range, tap  and select the time range.

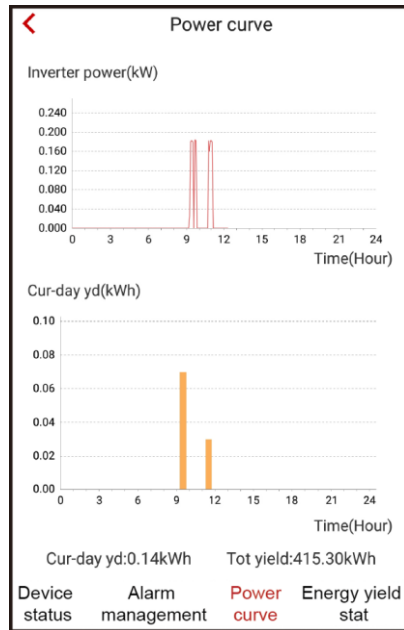
Figure 7-15 Alarm management



## Querying Power Curves

You can query the current-day power curve and energy yield.

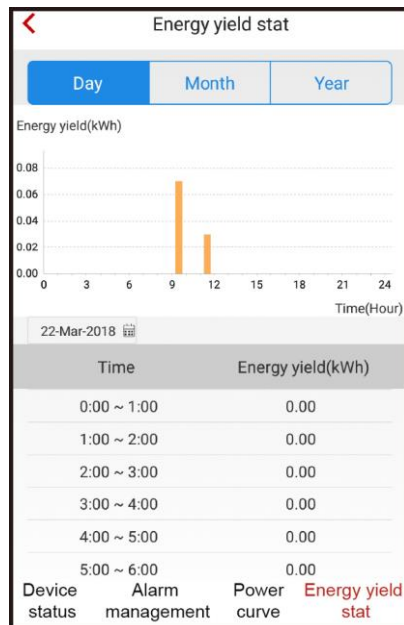
**Figure 7-16** Querying power curves



## Querying Energy Yields

You can query daily, monthly, and yearly energy yields.

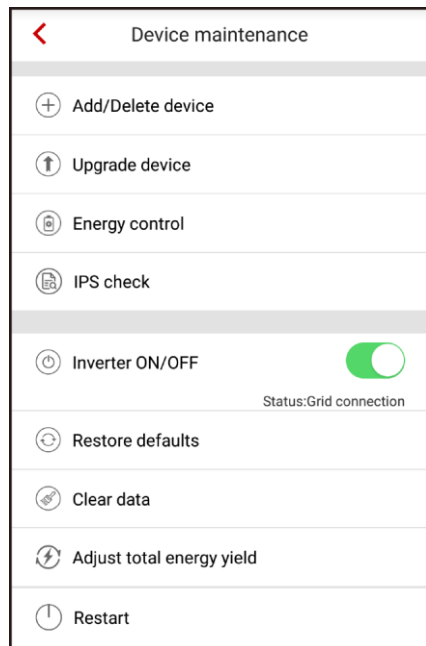
**Figure 7-17** Querying energy yields



## 7.4.3 Maintaining the SUN2000L

To maintain the SUN2000L, choose **Device maint** from the **Operation console** screen.

**Figure 7-18** Device maintenance



 **NOTE**

The **IPS check** function is available only for the Italy CEI0-21 grid code.

### 7.4.3.1 Adding/Deleting Devices

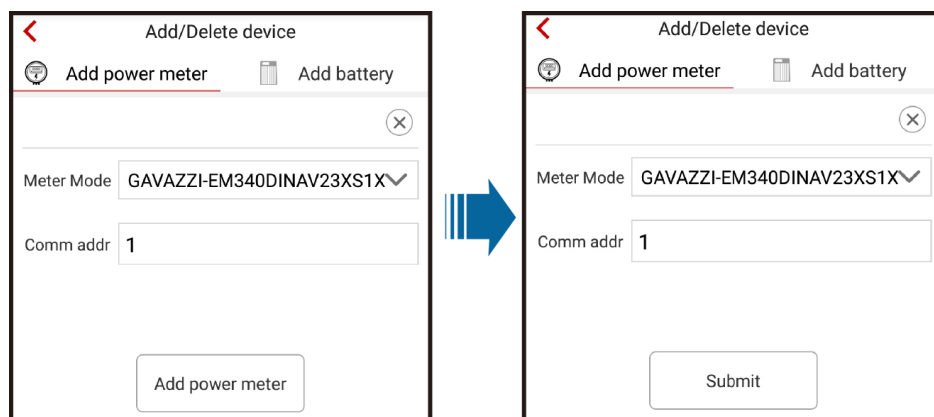
#### Procedure

- Step 1** On the **Operation console** screen, choose **Device maint** > **Add/Delete device**, and add a power meter and battery according to actual conditions. Tap **Submit** to deliver the device information to the SUN2000L.

 **NOTE**

Each device must have a unique communications address.

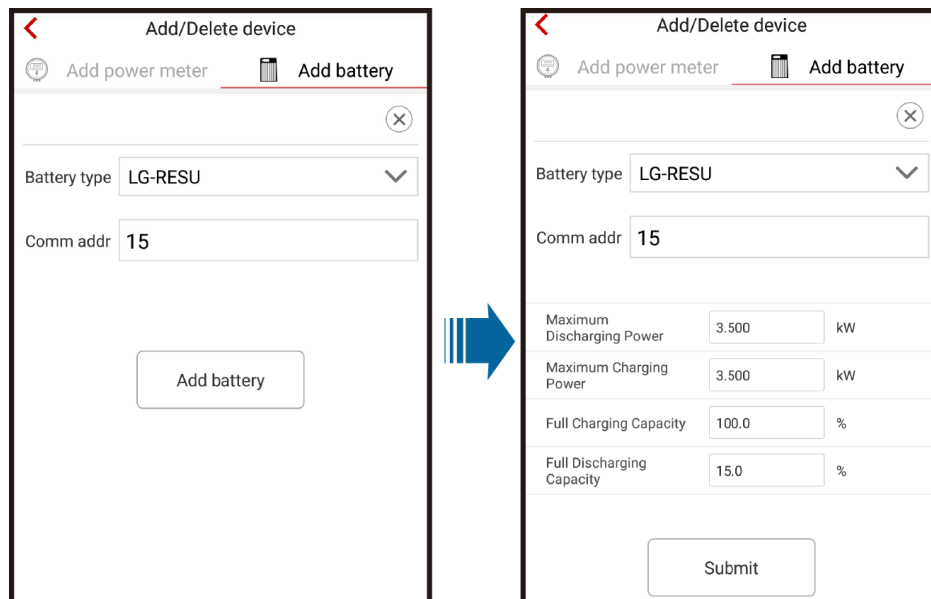
**Figure 7-19** Adding/Deleting power meter



**Table 7-1** Description of the parameters on the **Add power meter** tab page

Parameter	Description	Value Range
Comm addr	Specifies the RS485 address for the connected power meter. The address should be the same as the actual address for the power meter.	[1, 247]
Meter type	Specifies the model of the connected power meter. No power meter of other models can be connected.	<ul style="list-style-type: none"> <li>• CHINT-DDSU666</li> <li>• CCS-WNC-3Y-400-MB</li> <li>• Gavazzi-EM340DINAV 23XS1X</li> <li>• Gavazzi-EM111DINAV 81XS1X</li> <li>• Gavazzi-EM112DINAV 01XS1X</li> </ul>

**Figure 7-20** Adding/Deleting battery



**Table 7-2** Description of the parameters on the **Add battery** tab page

Parameter	Description	Value Range
Battery type	Specifies the model of the connected battery. No battery of other models can be connected.	LG-RESU



Parameter	Description	Value Range
Comm addr	Specifies the RS485 address for the connected battery. The address should be the same as the actual address for the battery.	[1, 247]
Maximum Charging Power (kW)	Specifies the maximum battery charging power.	[0, 3.500]
Maximum Discharging Power (kW)	Specifies the maximum battery discharging power.	[0, 3.500]
Full Charging Capacity (%)	Specifies the battery charging cutoff capacity.	[90.0, 100.0]
Full Discharging Capacity (%)	Specifies the battery discharging cutoff capacity.	[12.0, 20.0]

----End

### 7.4.3.2 Upgrading the Device

#### Prerequisites

You have obtained the upgrade file with the help of your supplier or Huawei engineers.

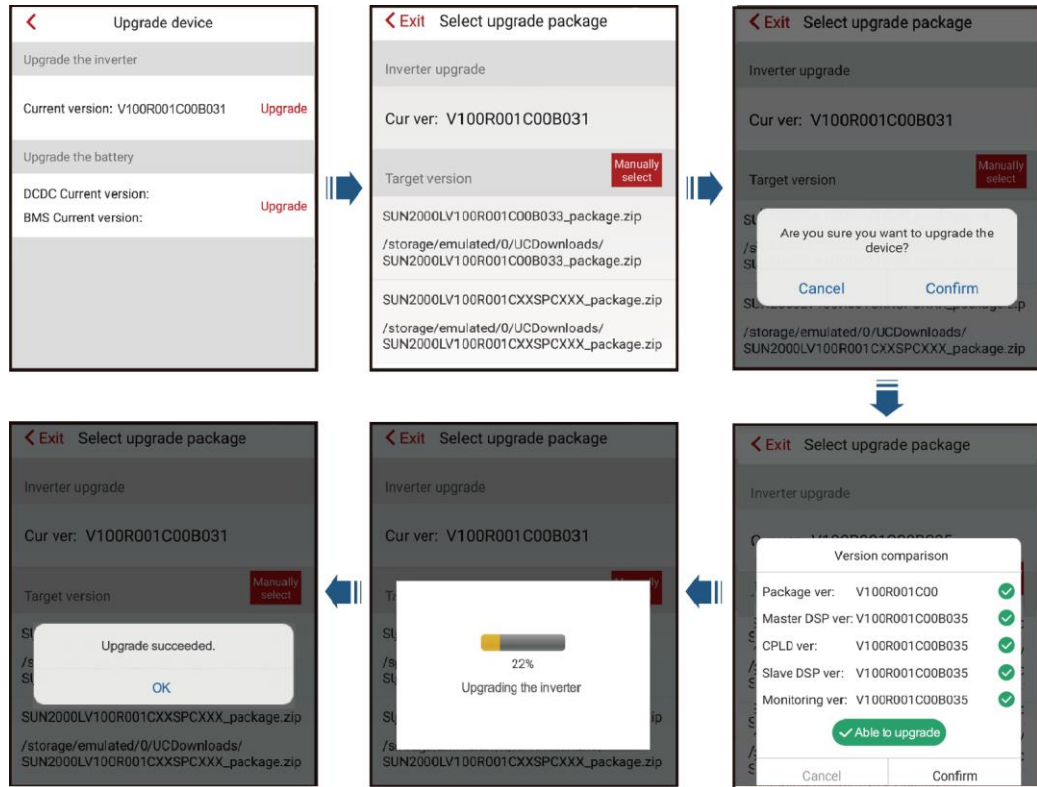
#### Context

- In the iOS system, the upgrade file can be imported to the mobile phone over your mailbox. The upgrade file name extension must be .zip. **Manually select** is unavailable.
- In the Android system, the upgrade file can be copied to the mobile phone. The upgrade file name extension must be .zip and the file can be stored in your required directory. **Manually select** is available.

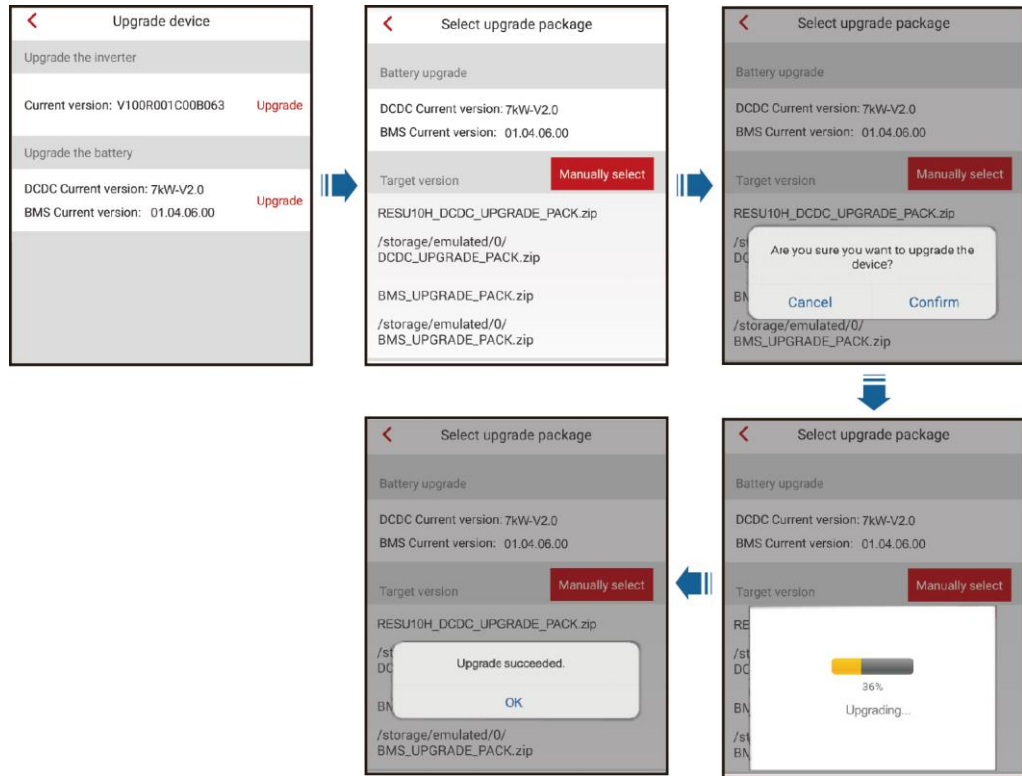
#### Procedure

- Step 1** On the **Operation console** screen, choose **Device maint** > **Upgrade device** and follow the instructions.

Figure 7-21 Upgrading the SUN2000L



**Figure 7-22** Upgrading the battery



**NOTE**

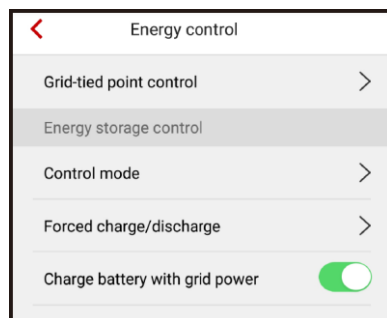
- There are DCDC and BMS upgrade packages for the battery. Choose one or both of the upgrade packages based on the actual situation.
- In the DCDC version, 7 kW corresponds to RESU10H and 5 kW corresponds to RESU7H.

----End

### 7.4.3.3 Energy Control

On the **Operation console** screen, choose **Device maintenance** > **Energy control** and perform the corresponding operation.

**Figure 7-23** Energy control

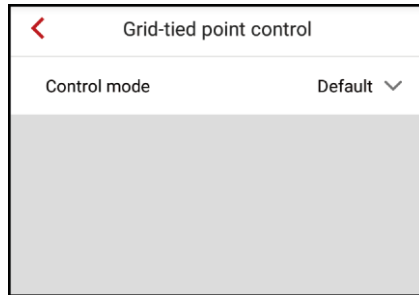


### 7.4.3.3.1 Grid-tied Point Control

#### Procedure

**Step 1** On the **Operation console** screen, choose **Device maint > Energy control > Grid-tied point control** and perform the required operation.

**Figure 7-24** Grid-tied point control



**Table 7-3** Description of control mode parameters

Parameter	Description	Value Range
Control mode	<p>If this parameter is set to <b>Default</b>, the SUN2000L output power is not limited. The SUN2000L can export its rated power to the power grid.</p> <p>If this parameter is set to <b>Grid connection with zero power</b> and the SUN2000L is connected to a power meter, the output power of the SUN2000L is supplied only to the local load, but not the power grid.</p> <p>If this parameter is set to <b>Power-limited Grid Connection</b> and the SUN2000L is connected to a power meter, the SUN2000L supplies power limited based on the setting of <b>Grid-tied Point Power</b> to the power grid.</p>	<ul style="list-style-type: none"> <li>• Default</li> <li>• Grid connection with zero power</li> <li>• Power-limited Grid Connection</li> </ul>

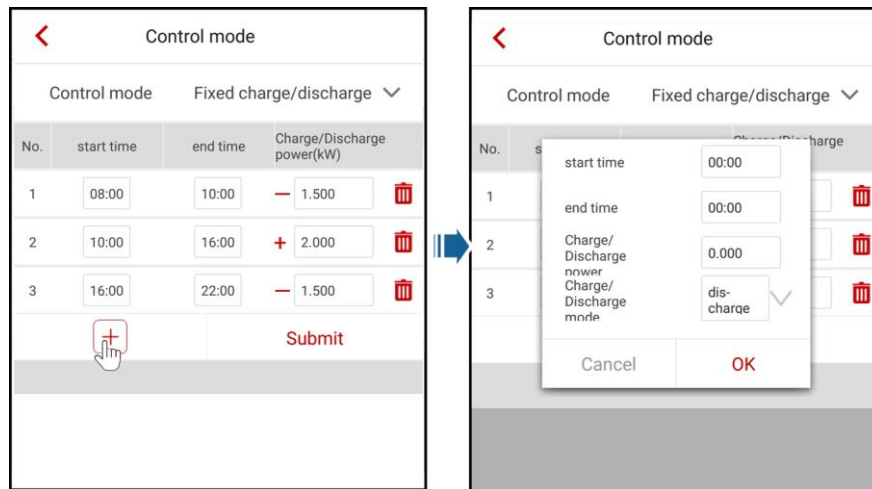
----End

### 7.4.3.3.2 Energy storage control

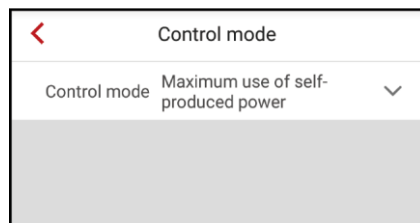
#### Control Mode

**Step 1** On the **Operation console** screen, choose **Device maint > Energy control > Energy storage control > Control mode** and perform the corresponding operation.

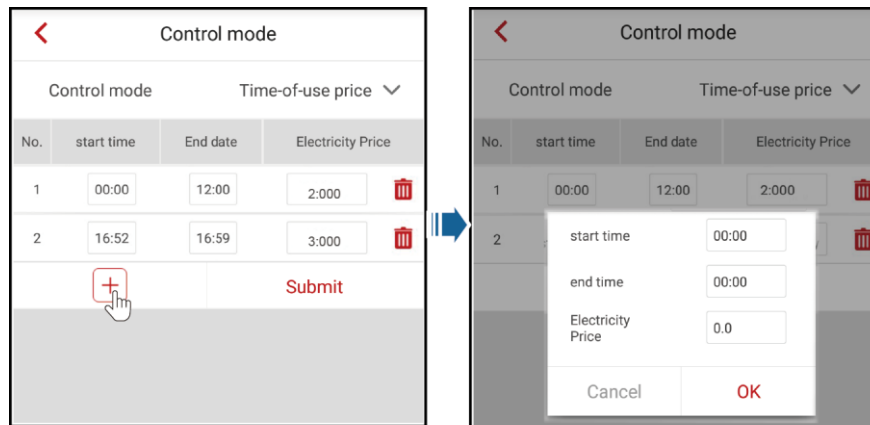
**Figure 7-25** Fixed charge/discharge



**Figure 7-26** Maximum use of self-produced power



**Figure 7-27** Time-of-use price



**Table 7-4** Description of energy storage control parameters

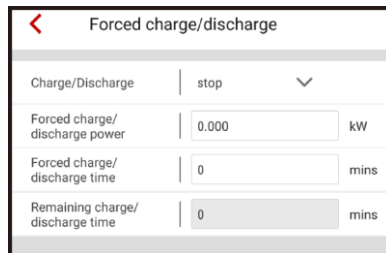
Parameter	Description	Value Range
Control mode	<ul style="list-style-type: none"> <li>If this parameter is set to <b>Fix chg/dis</b>, charging or discharging is allowed during the configured period. A maximum of 10 time periods can be added.</li> <li>If this parameter is set to <b>Maximum use of self-produced power</b> and the SUN2000L is connected to a power meter, the output power of the SUN2000L is supplied to the local load and the surplus power is supplied to the power grid.</li> <li>If this parameter is set to <b>Time-of-use price</b>, the battery is discharged when the electricity price is high and charged during other periods. 1/2 of higher prices among added electricity prices are high electricity prices. A maximum of 10 time periods can be added.</li> </ul>	<ul style="list-style-type: none"> <li>Fix chg/dis</li> <li>Maximum use of self-produced power</li> <li>Time-of-use price</li> </ul>

----End

## Forced Charge/Discharge

**Step 1** On the **Operation console** screen, choose **Device maint > Energy control > Energy storage control > Forced charge/discharge** and perform the corresponding operation.

**Figure 7-28** Forced charge/discharge



**Table 7-5** Description of forced charge/discharge parameters

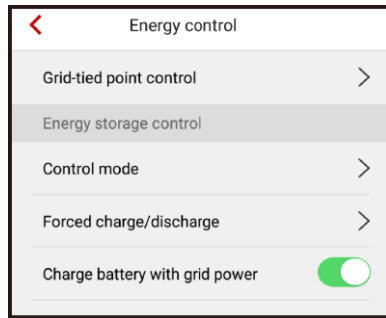
Parameter	Description	Value Range
Charge/discharge power	Specifies the forced charge/discharge control mode.	<ul style="list-style-type: none"> <li>Stop</li> <li>Charge power</li> <li>Discharge power</li> </ul>
Forcible chg/dis pwr (kW)	Specifies the forced charge/discharge power.	<ul style="list-style-type: none"> <li>Charge: [0, Maximum charge power]</li> <li>Discharge: [0, Maximum discharge power]</li> </ul>
Forcible chg/dis time (mins)	Specifies the forced charge/discharge duration.	[0, 1440]
Remaining charge/discharge time (mins)	Displays the remaining charge/discharge time. This Parameter cannot be set.	[0, 1440]

----End

## Charge battery with grid power

**Step 1** On the **Operation console** screen, choose **Device maint > Energy control > Energy storage control > Charge battery with grid power** and perform the corresponding operation.

**Figure 7-29** Charge battery with grid power



**Table 7-6** Parameter description of Charge battery with grid power

Parameter	Description	Value Range
Charge battery with grid power	The power grid will charge the battery if <b>Charge battery with grid power</b> is enabled.  <b>Charge battery with grid power</b> is set to <b>Disable</b> by default. If this function is enabled, comply with the grid charge requirements stipulated in local laws and regulations.	<ul style="list-style-type: none"> <li>• Disable</li> <li>• Enable</li> </ul>

----End

### 7.4.3.4 IPS Check (for Italy CEI0-21 Grid Code only)

#### Context

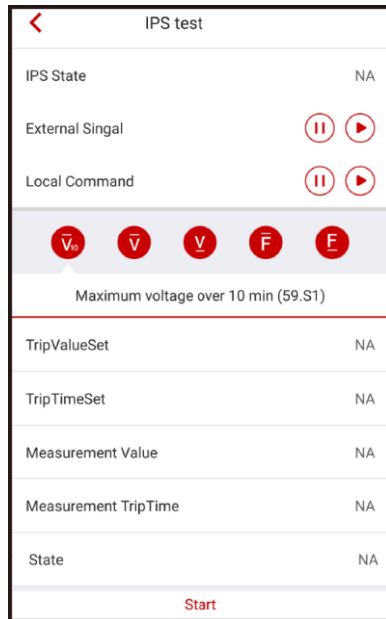
The Italy CEI0-21 grid code requires IPS check for the SUN2000L. During the self-check process, the SUN2000L consecutively checks the protection thresholds and time for 10-min overvoltage, level 1 overvoltage, level 1 undervoltage, level 1 overfrequency, and level 1 underfrequency. The SUN2000L shuts down after the check starts, and it restarts after the check is successful.

#### Procedure

- Step 1** On the **Operation console** screen, choose **Device maint** > **IPS check** to access the IPS check screen.





**Figure 7-30** IPS test



**Step 2** Choose to start the S1 or S2 check as required. The default check type is S1. To start the S2 check, you need to set **External Signal** or **Local Command**.

**Table 7-7** Check type description

Check Type	Description	External Signal Setting	Local Command Setting
S1 (default)	The level 1 overfrequency protection threshold is 50.5 Hz and the level 1 underfrequency protection threshold is 49.5 Hz.		
S2	The level 1 overfrequency protection threshold is 51.5 Hz and the level 1 underfrequency protection threshold is 47.5 Hz.		
S2	The level 1 overfrequency protection threshold is 51.5 Hz and the level 1 underfrequency protection threshold		

Check Type	Description	External Signal Setting	Local Command Setting
	is 47.5 Hz.		
S2	The level 1 overfrequency protection threshold is 51.5 Hz and the level 1 underfrequency protection threshold is 47.5 Hz.		

**Step 3** Tap **Start** to start the check. After the check is complete, **IPS State** is displayed as **Self-test success**.

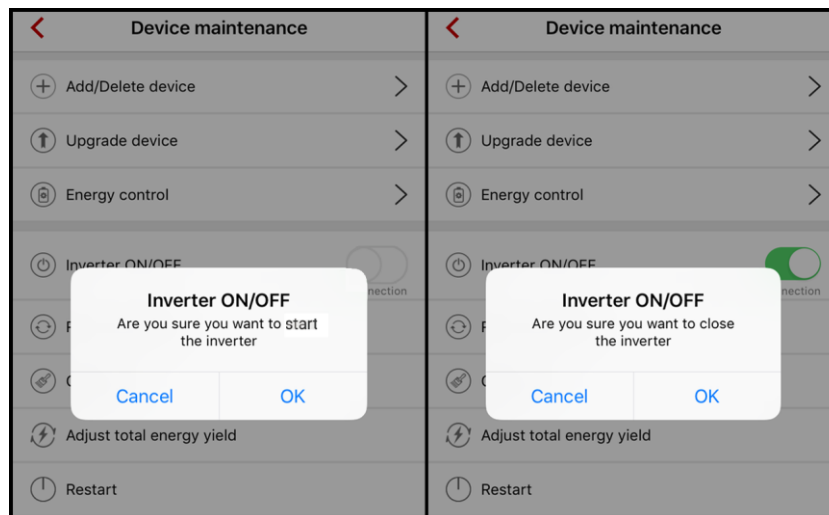
----End

### 7.4.3.5 Starting or Shutting Down the SUN2000L

#### Procedure

**Step 1** On the **Operation console** screen, choose **Device maint** > **Inverter ON/OFF**, and perform operations as required.

**Figure 7-31** Starting or shutting down the SUN2000L



 **NOTE**

To start or shut down the SUN2000L, you need to re-enter the password for second authentication.

----End

### 7.4.3.6 Restoring Factory Defaults

#### Context

---

**NOTICE**

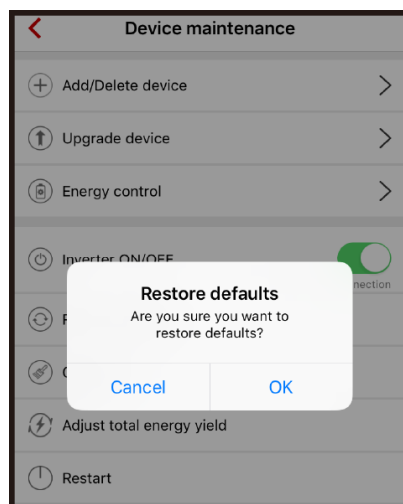
Perform this operation with caution because all configured parameters except the current date, time, and networking parameters will be restored to their factory defaults. This operation will not affect operating information, alarm records, and system logs.

---

#### Procedure

- Step 1** On the **Operation console** screen, choose **Device maint** > **Restore defaults**, and then tap **Confirm**.

**Figure 7-32** Restoring factory defaults

**NOTE**

To restore factory defaults, you need to re-enter the password for second authentication.

----End

### 7.4.3.7 Clearing Data

#### Context

---

**NOTICE**

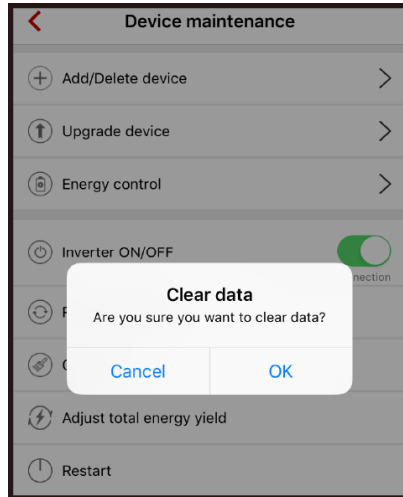
If you clear data, all the alarm and energy yield data will be cleared.

---

## Procedure

**Step 1** On the **Operation console** screen, choose **Device maint** > **Clear data**.

**Figure 7-33** Clearing data



### NOTE

To clear data, you need to re-enter the password for second authentication.

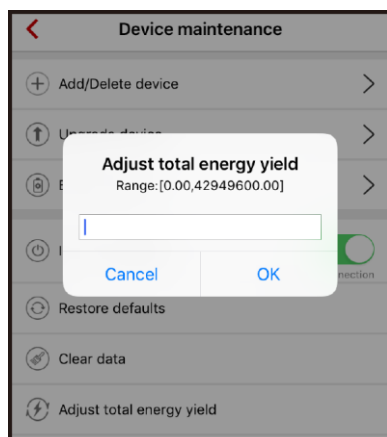
----End

## 7.4.3.8 Adjusting Total Energy Yield

### Procedure

**Step 1** On the **Operation console** screen, choose **Device maint** > **Adjust total energy yield**.

**Figure 7-34** Adjusting total energy yield



 **NOTE**

- To adjust the total energy yield of the SUN2000L, you need to re-enter the password for second authentication.
- Adjusting total energy yield: specifies the initial energy yield of the SUN2000L. This parameter is used in SUN2000L replacement scenarios. Set the initial energy yield of the new SUN2000L to the total energy yield of the old SUN2000L to ensure continuous statistics of cumulative energy yield.

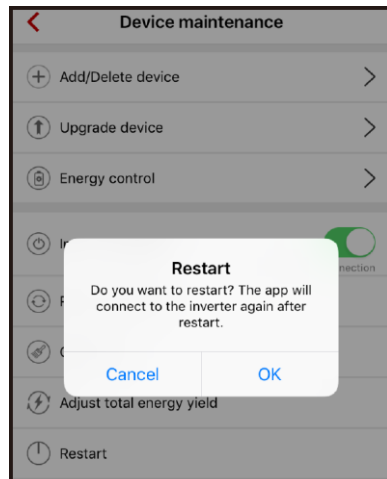
----End

## 7.4.3.9 Restart

### Procedure

**Step 1** On the **Operation console** screen, choose **Device maint** > **Restart**.

**Figure 7-35** Restart



 **NOTE**

To restart the SUN2000L, you need to re-enter the password for second authentication.

----End

## 7.4.4 Quick Setting

To enter the **Quick setting** screen, choose **Quick setting** from the **Operation console** screen.

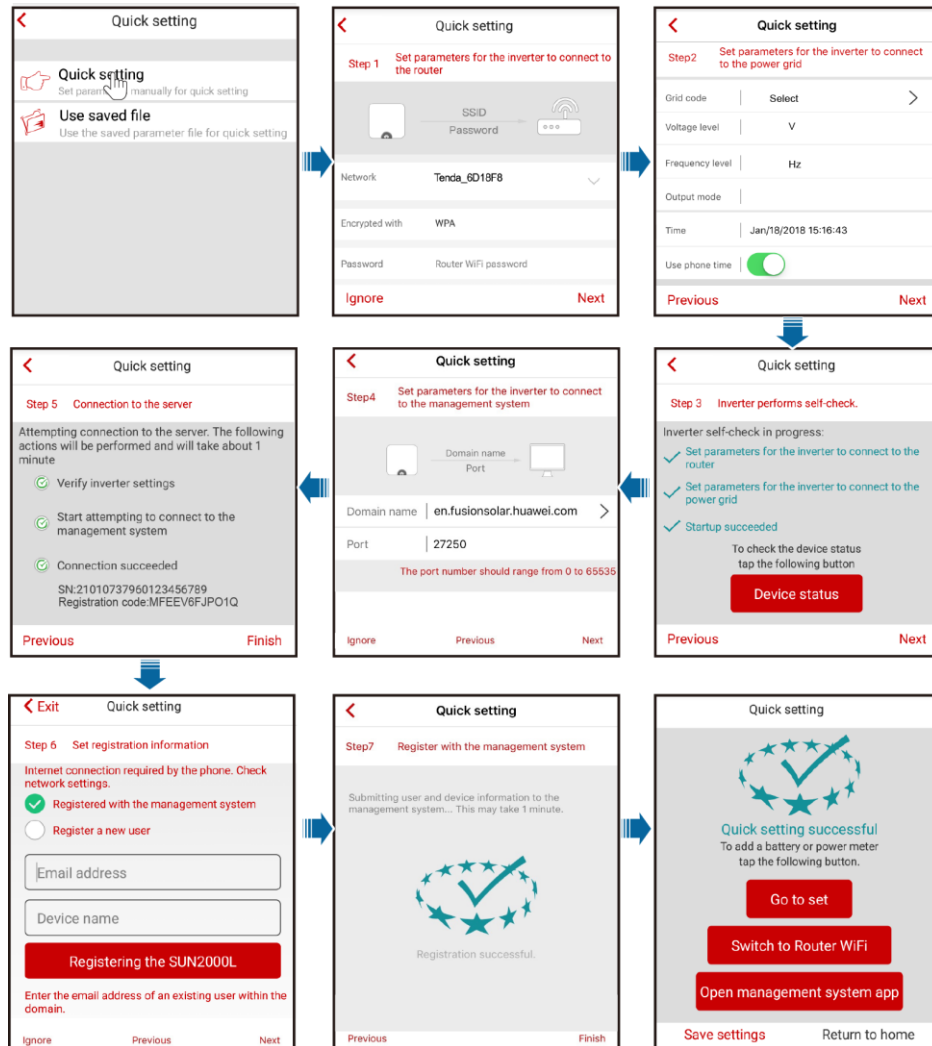
The **Quick setting** screen provides two deployment modes. Select either of them based on site requirements.

To exit the setting, press the **Back** button on the mobile phone or tap **Exit** on the screen.

### Method 1: Quick Setting

**Step 1** Choose **Quick setting** from the **Operation console** screen and perform setting by following the instructions.

Figure 7-36 Quick setting



**NOTE**

The app allows for two methods to register with the management system:

- The domain name can be selected by the right button in step 4.
- If you have registered in step 6, enter the email address and device name, and click **Next** or **Registering the SUN2000L**.
- If you have not registered in step 6, tap **Register a new user** to enter information for registration.
- Before tapping **Next** or **Registering the SUN2000L**, ensure that the mobile phone is connected to the Internet.



## NOTICE

- Set the grid code that applies to the country or region where the PV plant is located and the SUN2000L model.
- If there is no need to connect to the router or management system, skip relevant steps.
- After the management system is successfully connected, the SUN2000L will report the SN and installer registration code. If the connection fails, another connection attempt will start after 10 seconds. The installer registration code is generated by the SUN2000L automatically and is used for the installer to register with the management system and manage the inverter.
- For the operations about how to add devices, see [7.4.3.1 Adding/Deleting Devices](#).
- After quick setting is complete, tap **Switch to Router WiFi** to switch to the **Available WiFi networks nearby** screen and tap the corresponding router WiFi connection to switch to the router WiFi network.
- To connect to the router WiFi network from the mobile phone system after router parameters are successfully set, you need to log out of the app and log in again.
- After following all the instructions on the **Quick setting** screen, tap **Save settings** to store the configurations or tap **Return to home** to return to the **Operation console** screen.

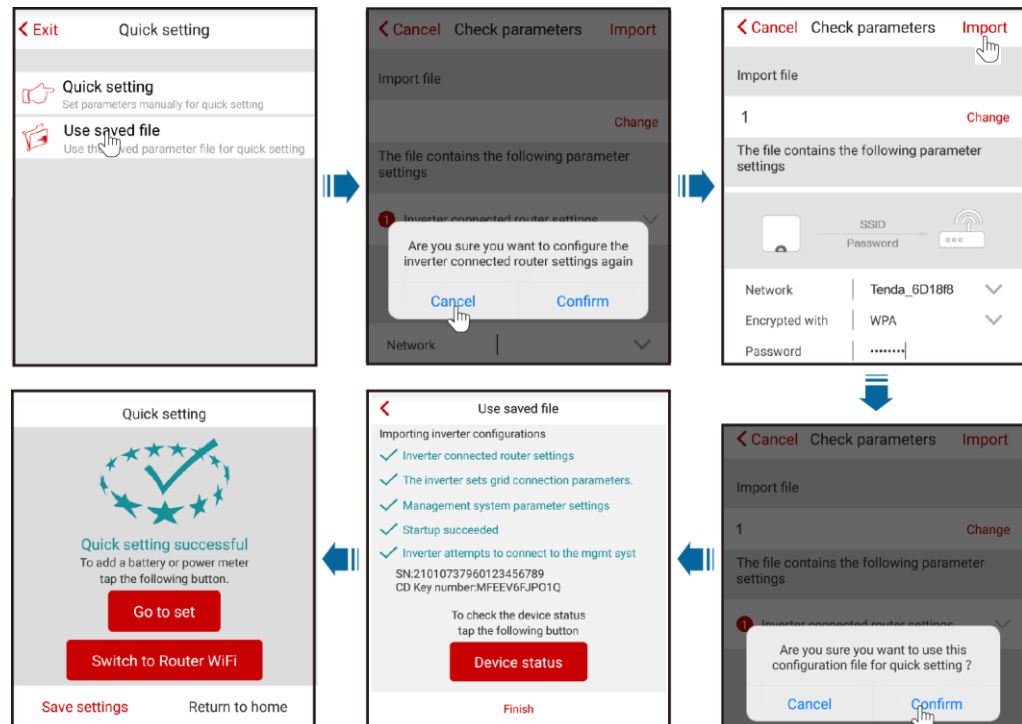
----End

## Method 2: use the saved file

Before choosing **Use saved file** for quick setting, ensure that the corresponding configuration file is saved on your mobile phone. To generate a configuration file, tap **Save settings** on the **Quick setting** screen.

- Step 1** Choose **Quick setting** > **Use saved file** from the **Operation console** screen and perform deployment by following the instructions.

**Figure 7-37** Performing quick setting using a saved file



**NOTE**

- To change the configuration file to be imported, tap **Change**.
- In the dialog box with **Are you sure you want to configure the inverter connected router settings again**, if you tap **Confirm**, the router configurations saved before will be cleared. If you tap **Cancel**, you only have to enter the saved router password.
- After quick setting is complete, tap **Switch to Router WiFi** to switch to the **Available WiFi networks nearby** screen and tap the corresponding router WiFi connection to switch to the router WiFi network.
- To connect to the router WiFi network from the mobile phone system after router parameters are successfully set, you need to log out of the app and log in again.
- After the management system is successfully connected, the SUN2000L will report the SN and installer registration code. If the connection fails, another connection attempt will start after 10 seconds. The installer registration code is generated by the SUN2000L automatically and is used for the installer to register with the management system and manage the inverter.

----End

## 7.4.5 Setting Grid-Connection Parameters

### Setting Grid-Connection Parameters

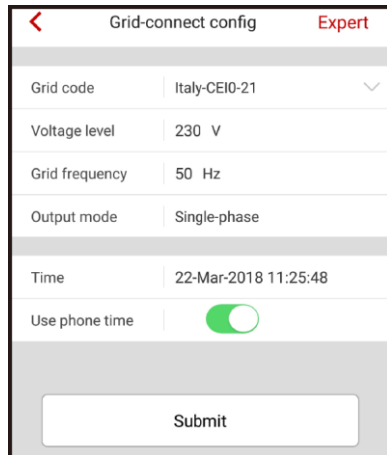
To set grid codes, choose **Grid-connect config** from the **Operation console** screen.

**NOTE**

**Voltage level**, **Grid frequency**, and **Output mode** do not have to be set because they are associated with the grid code.



**Figure 7-38** Grid-connect config



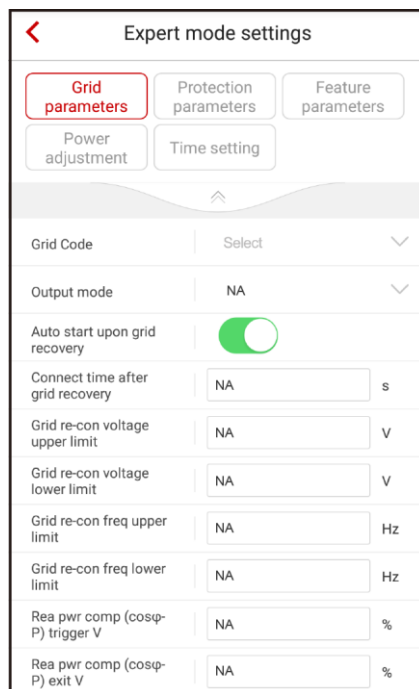
## Expert Mode

To set grid parameters, protection parameters, feature parameters, power adjustment parameters, and time in expert mode, choose **Grid-connect config > Expert** from the **Operation console** screen.

### 7.4.5.1 Grid Parameters

To set grid parameters, choose **Grid-connect config > Expert > Grid parameters** from the **Operation console** screen.

**Figure 7-39** Grid parameters





**NOTE**

- $V_n$  represents the rated voltage and  $F_n$  represents the rated frequency.
- The grid parameter values vary with grid codes. The displayed values prevail.

**Table 7-8** Description of grid parameters

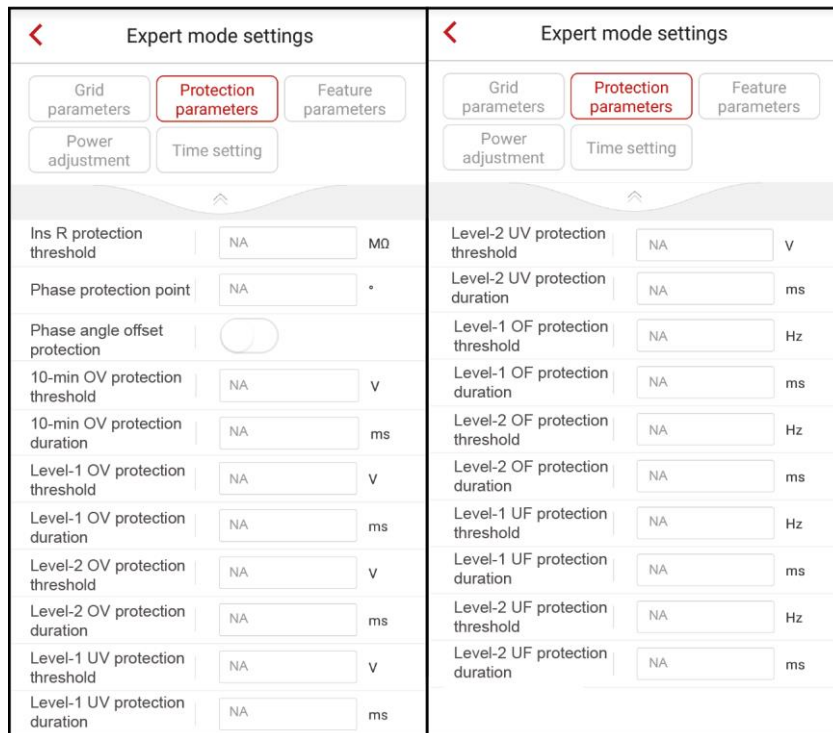
Parameter	Description	Value Range
Grid code	Set this parameter based on the grid code of the country or region where the SUN2000L is used and the SUN2000L application scenario. For details of the grid codes, see <a href="#">A Grid Codes</a> .	The default value varies with on the model. The displayed value prevails.
Output mode		<ul style="list-style-type: none"> <li>• Single-phase</li> <li>• Split-phase</li> <li>• Dual-live wire</li> </ul>
Auto start upon grid recovery	Specifies whether the SUN2000L can start automatically when the power grid recovers.	<ul style="list-style-type: none"> <li>• Disable</li> <li>• Enable</li> </ul>
Connect time after grid recovery (s)	Specifies the time after which the SUN2000L begins restarting after the power grid recovers.	[0, 900]
Grid re-con voltage upper limit (V)	For a specific grid code, if the grid voltage exceeds the upper threshold, the SUN2000L is not allowed to connect to the power grid.	[100% $V_n$ , 136% $V_n$ ]
Grid re-con voltage lower limit (V)	For a specific grid code, if the grid voltage is below the lower threshold, the SUN2000L is not allowed to connect to the power grid.	[45% $V_n$ , 95% $V_n$ ]
Grid re-con freq upper limit (Hz)	For a specific grid code, if the grid frequency exceeds the upper threshold, the SUN2000L is not allowed to connect to the power grid.	[100% $F_n$ , 112% $F_n$ ]
Grid re-con freq lower limit (Hz)	For a specific grid code, if the grid frequency is below the lower threshold, the SUN2000L is not allowed to connect to the power grid.	[85% $F_n$ , 100% $F_n$ ]
Rea pwr comp ( $\cos\phi$ -P) trigger V (%)	Specifies the voltage threshold for triggering reactive power compensation when low voltage ride-through	[100, 110]

Parameter	Description	Value Range
	(LVRT) occurs.	
Rea pwr comp (cosφ-P) exit V (%)	Specifies the voltage threshold for exiting reactive power compensation when the SUN2000L recovers from LVRT.	[90, 100]

### 7.4.5.2 Protection Parameters

To set protection parameters, choose **Grid-connect config > Expert > Protection parameters** from the **Operation console** screen.

**Figure 7-40** Protection parameters



**NOTE**

- $V_n$  represents the rated voltage and  $F_n$  represents the rated frequency.
- The protection parameter values vary with grid codes. The displayed values prevail.

**Table 7-9** Description of protection parameters

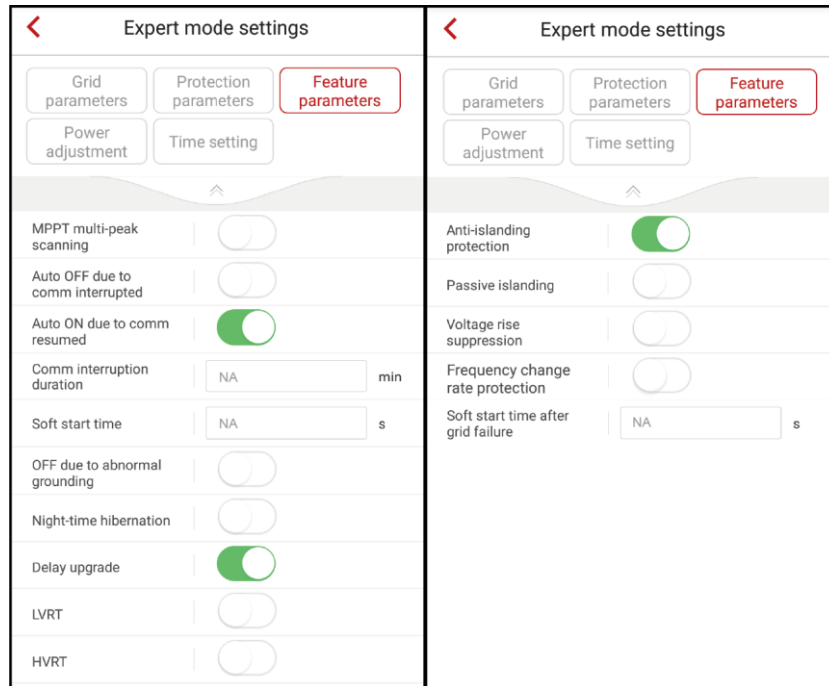
Parameter	Description	Value Range
Ins R protection threshold (MΩ)	To ensure device safety, the SUN2000L detects the insulation resistance of the input side to the ground when it starts a self-check. If the detected value is less than the preset value, the SUN2000L does not start.	[0.02, 1.5]
Phase protection point (°)	The requires that during passive islanding detection, protection should be triggered if an abrupt voltage phase change is detected.	[3, 15]
Phase angle offset protection	Under a specific grid code, the SUN2000L needs to be protected when the phase angle offset of the three phases of the power grid exceeds a certain value.	<ul style="list-style-type: none"> <li>• Enable</li> <li>• Disable</li> </ul>
10-min OV protection threshold (V)	Specifies the 10-minute overvoltage protection threshold.	[1xVn, 1.5xVn]
10-min OV protection duration (ms)	Specifies the 10-minute overvoltage protection duration.	[50, 7200000]
Level-1 OV protection threshold (V)	Specifies the level-1 overvoltage protection threshold.	[1xVn, 1.5xVn]
Level-1 OV protection duration (ms)	Specifies the level-1 overvoltage protection duration.	[50, 7200000]
Level-2 OV protection threshold (V)	Specifies the level-2 overvoltage protection threshold.	[1xVn, 1.5xVn]
Level-2 OV protection duration (ms)	Specifies the level-2 overvoltage protection duration.	[50, 7200000]
Level-1 UV protection threshold (V)	Specifies the level-1 undervoltage protection threshold.	[0.15xVn, 1xVn]
Level-1 UV protection duration (ms)	Specifies the level-1 undervoltage protection duration.	[50, 7200000]

Parameter	Description	Value Range
Level-2 UV protection threshold (V)	Specifies the level-2 undervoltage protection threshold.	[0.15xVn, 1xVn]
Level-2 UV protection duration (ms)	Specifies the level-2 undervoltage protection duration.	[50, 7200000]
Level-1 OF protection threshold (Hz)	Specifies the level-1 overfrequency protection threshold.	[1xFn, 1.15xFn]
Level-1 OF protection duration (ms)	Specifies the level-1 overfrequency protection duration.	[50, 7200000]
Level-2 OF protection threshold (Hz)	Specifies the level-2 overfrequency protection threshold.	[1xFn, 1.15xFn]
Level-2 OF protection duration (ms)	Specifies the level-2 overfrequency protection duration.	[50, 7200000]
Level-1 UF protection threshold (Hz)	Specifies the level-1 underfrequency protection threshold.	[0.85xFn, 1xFn]
Level-1 UF protection duration (ms)	Specifies the level-1 underfrequency protection duration.	[50, 7200000]
Level-2 UF protection threshold (Hz)	Specifies the level-2 underfrequency protection threshold.	[0.85xFn, 1xFn]
Level-2 UF protection duration (ms)	Specifies the level-2 underfrequency protection duration.	[50, 7200000]

### 7.4.5.3 Feature Parameters

To set feature parameters, choose **Grid-connect config > Expert > Feature parameters** from the **Operation console** screen

**Figure 7-41** Feature parameters



**NOTE**

The feature parameter values vary with grid codes. The displayed values prevail.

**Table 7-10** Description of feature parameters

Parameter	Description	Value Range
MPPT multi-peak scanning	When the SUN2000L is used in scenarios where PV strings are obviously shaded, enable this function. Then the SUN2000L will perform MPPT scanning for all PV strings at regular intervals to locate the maximum power.  The scan interval is specified by <b>MPPT multi-peak scan interval</b> .	<ul style="list-style-type: none"> <li>• Disable</li> <li>• Enable</li> </ul>
MPPT multi-peak scan interval (min)	Specifies the MPPT multi-peak scanning interval.  This parameter is displayed only when <b>MPPT multi-peak scanning</b> is set to <b>Enable</b> .	[5, 30]

Parameter	Description	Value Range
Auto OFF due to comm interrupted	<p>Certain power grids require that the SUN2000L shut down after the communication is interrupted for a certain period of time.</p> <p>If <b>Auto OFF due to comm interrupted</b> is set to <b>Enable</b> and the SUN2000L communication is interrupted for a period of time specified by <b>Comm interruption duration</b>), the SUN2000L will automatically shut down.</p>	<ul style="list-style-type: none"> <li>• Disable</li> <li>• Enable</li> </ul>
Auto ON due to comm resumed	<p>If this parameter is enabled, the SUN2000L automatically starts after communication recovers. If this parameter is disabled, the SUN2000L needs to be started manually after communication recovers.</p>	<ul style="list-style-type: none"> <li>• Disable</li> <li>• Enable</li> </ul>
Comm interruption duration (min)	<p>Specifies the duration for determining communication interruption. Used for automatic shutdown for protection in case of communication interruption.</p>	[1, 120]
Soft start time (s)	<p>Specifies the duration for the power to gradually increase when the SUN2000L starts.</p>	[20, 1800]

Parameter	Description	Value Range
OFF due to abnormal grounding	<p>This function is used to detect whether the SUN2000L is properly grounded before starting it, or to detect whether the PE cable is disconnected when the SUN2000L is working. This parameter is set to <b>Enable</b> by default. For certain types of power grids, if an isolation transformer connects to the output side of the SUN2000L, you need to set <b>OFF due to abnormal grounding</b> to <b>Disable</b> after checking that the SUN2000L is properly grounded. Then the SUN2000L can start normally.</p> <p>If you are not sure whether the SUN2000L connects to such a power grid, confirm it with your supplier or Huawei technical support.</p>	<ul style="list-style-type: none"> <li>• Disable</li> <li>• Enable</li> </ul>
Night-time hibernation	<p>The SUN2000L monitors PV strings at night. If <b>Night-time hibernation</b> is set to <b>Enable</b>, the monitoring function of the SUN2000L will hibernate at night, reducing power consumption.</p>	<ul style="list-style-type: none"> <li>• Disable</li> <li>• Enable</li> </ul>
Delay upgrade	<p>This parameter is mainly used in the upgrade scenarios where the PV power supply is disconnected at night when there is no sunlight or the power supply is unstable at dawn or dusk due to poor sunlight.</p>	<ul style="list-style-type: none"> <li>• Disable</li> <li>• Enable</li> </ul>
LVRT	<p>When the grid voltage is abnormally low for a short time, the SUN2000L cannot disconnect from the power grid immediately and has to work for a period of time. This is called LVRT.</p>	<ul style="list-style-type: none"> <li>• Disable</li> <li>• Enable</li> </ul>



Parameter	Description	Value Range
Threshold for triggering LVRT (V)	Specifies the threshold for triggering LVRT. This parameter is displayed only when <b>LVRT</b> is set to <b>Enable</b> .	[50% Vn, 92% Vn]
LVRT undervoltage protection shield	Specifies whether to shield the undervoltage protection function during LVRT.	<ul style="list-style-type: none"> <li>• Disable</li> <li>• Enable</li> </ul>
LVRT reactive power comp factor	During LVRT, the SUN2000L needs to generate reactive power to support the power grid. This parameter specifies the reactive power generated by the SUN2000L. This parameter is displayed only when <b>LVRT undervoltage protection shield</b> is set to <b>Enable</b> .	[0, 3]
HVRT	When the grid voltage is abnormally high for a short time, the SUN2000L cannot disconnect from the power grid immediately and has to work for a period of time. This is called high voltage ride-through (HVRT).	<ul style="list-style-type: none"> <li>• Disable</li> <li>• Enable</li> </ul>
HVRT threshold	Specifies the threshold for triggering HVRT. This parameter is displayed only when <b>HVRT</b> is set to <b>Enable</b> .	[105% Vn, 130% Vn]
Anti-islanding protection	Specifies whether to enable the active islanding protection function.	<ul style="list-style-type: none"> <li>• Disable</li> <li>• Enable</li> </ul>
Passive islanding	Specifies whether to enable the passive islanding protection function.	<ul style="list-style-type: none"> <li>• Disable</li> <li>• Enable</li> </ul>
Voltage rise suppression	For a specific grid code requires that the active power of the SUN2000L be derated according to a certain slope when the output voltage exceeds a certain value.	<ul style="list-style-type: none"> <li>• Disable</li> <li>• Enable</li> </ul>

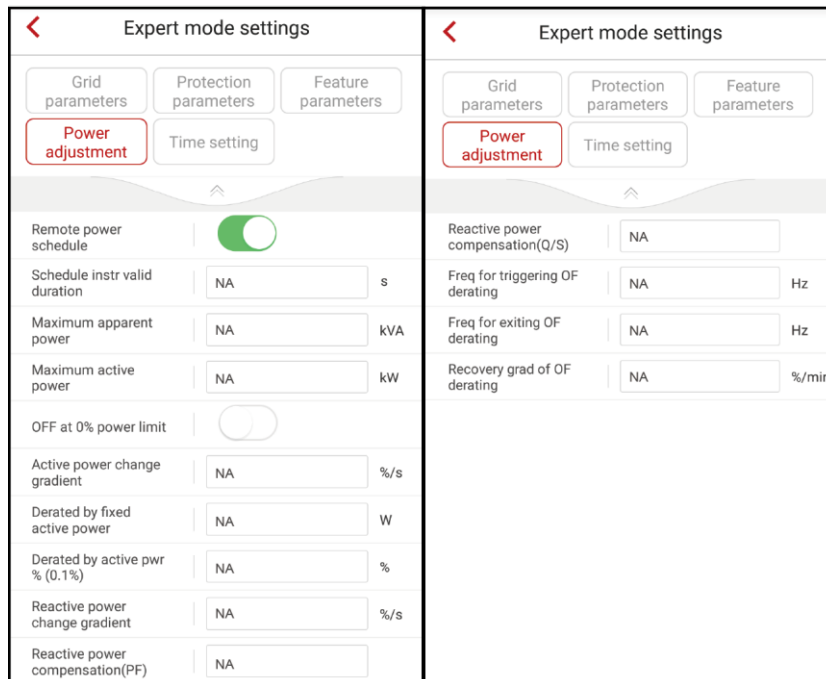
Parameter	Description	Value Range
V rise suppress reactive adjust point (%)	For a specific grid code requires that the SUN2000L generate a certain amount of reactive power when the output voltage exceeds a certain value.  This parameter is displayed when <b>Voltage rise suppression</b> is set to <b>Enable</b> .	[100, 115]
V rise suppress active derating point (%)	For a specific grid code requires that the active power of the SUN2000L be derated according to a certain slope when the output voltage exceeds a certain value.  This parameter is displayed when <b>Voltage rise suppression</b> is set to <b>Enable</b> .  <b>V rise suppress active derating pt</b> must be greater than <b>V rise suppress reactive adjust pt</b> .	[100, 115]
Frequency change rate protection	Specifies whether to protect the SUN2000L when the grid frequency changes too fast.	<ul style="list-style-type: none"> <li>• Enable</li> <li>• Disable</li> </ul>
Freq chg rate protection threshold (Hz/s)	For a specific grid code, the SUN2000L is protected when the grid frequency change rate exceeds the value.  This parameter is displayed if <b>Frequency change rate protection</b> is set to <b>Enable</b> .	[0.1, 5]
Freq chg rate protection duration (s)	The SUN2000L is protected when the grid frequency change duration exceeds the value.  This parameter is displayed if <b>Frequency change rate protection</b> is set to <b>Enable</b> .	[0.2, 20]

Parameter	Description	Value Range
Soft start time after grid failure (s)	Specifies the time for the power to gradually increase when the SUN2000L restarts after the power grid recovers.	[20, 800]

### 7.4.5.4 Power Adjustment

To set power adjustment parameters, choose **Grid-connect config > Expert > Power adjustment** from the **Operation console** screen.

**Figure 7-42** Power adjustment



 **NOTE**

The power adjustment parameter values vary with grid codes. The displayed values prevail.

**Table 7-11** Description of power adjustment parameters

Parameter	Description	Value Range
Remote power schedule	If <b>Remote power schedule</b> is disabled, the SUN2000L will not follow the remote power scheduling instruction.	<ul style="list-style-type: none"> <li>• Disable</li> <li>• Enable</li> </ul>

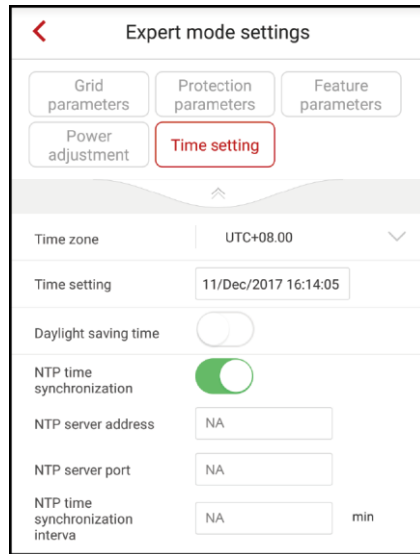
Parameter	Description	Value Range
Schedule instr valid duration (s)	Adjusts the duration within which the scheduling instruction is valid. If this parameter is set to <b>0</b> , the instruction is valid permanently.	[0, 86400]
Maximum apparent power (kVA)	Specifies the output upper threshold for the maximum apparent power to adapt to the capacity requirements for standard transformers and customized transformers.  If the maximum active power equals Smax_limit, this parameter is not displayed.	[Maximum active power, Smax_limit]
Maximum active power (kW)	Specifies the output upper threshold for the maximum active power to adapt to different market requirements.	[0.1, Pmax_limit]
OFF at 0% power limit	If this parameter is set to <b>Enable</b> , the SUN2000L shuts down after receiving the 0% power limit instruction. If this parameter is set to <b>Disable</b> , the SUN2000L does not shut down after receiving the 0% power limit instruction.	<ul style="list-style-type: none"> <li>• Disable</li> <li>• Enable</li> </ul>
Active power change gradient (%/s)	Adjusts the change speed of the SUN2000L active power.	[0.1, 1000]
Derated by fixed active power (W)	Adjusts the active power output of the SUN2000L in form of fixed values. Pmax refers to the maximum active power.	[0, Pmax_limit]
Derated by active pwr % (0.1%)	Adjusts the active power output of the SUN2000L to a percentage. If this parameter is set to <b>100</b> , the SUN2000L delivers its maximum output power.	[0, 100]

Parameter	Description	Value Range
Reactive power change gradient (%/s)	Adjusts the change speed of the SUN2000L reactive power.	[0.1, 1000]
Reactive power compensation (PF)	Adjusts the SUN2000L output power factor.	(-1, -0.8]U[0.8, 1]
Reactive power compensation (Q/S)	Adjusts the SUN2000L output reactive power.	[-0.6, 0.6]
Freq for triggering OF derating (Hz)	For a specific grid code, the SUN2000L output active power needs to be derated when the grid frequency exceeds a specific value.	<ul style="list-style-type: none"> <li>When the output frequency is 50 Hz, the value range is 45.00–55.00 Hz.</li> <li>When the output frequency is 60 Hz, the value range is 55.00–65.00 Hz.</li> </ul>
Freq for exiting OF derating (Hz)	Specifies the frequency threshold for exiting overfrequency derating.	<ul style="list-style-type: none"> <li>When the output frequency is 50 Hz, the value range is 45.00–55.00 Hz.</li> <li>When the output frequency is 60 Hz, the value range is 55.00–65.00 Hz.</li> </ul>
Recovery grad of OF derating (%/min)	Specifies the power recovery gradient for overfrequency derating.	[5, 20]

### 7.4.5.5 Time setting

To set time, choose **Grid-connect config > Expert > Time setting** from the **Operation console** screen.

**Figure 7-43** Time setting



**Table 7-12** Description of time setting parameters

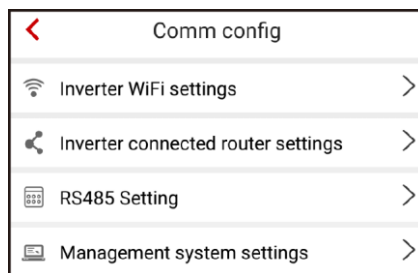
Parameter	Description	Value Range
Time zone	Specifies the time zone.	N/A
Time setting	Specifies the time.	N/A
Daylight saving time	Specifies the daylight saving time (DST).	<ul style="list-style-type: none"> <li>• Disable</li> <li>• Enable</li> </ul>
Daylight saving time settings (min)	Specifies the DST offset. This parameter is displayed if <b>Daylight saving time</b> is set to <b>Enable</b> .	[-240, 240]
Start date	Specifies the DST offset start date.	[01-01, 12-31]
Start time	Specifies the DST offset start time.	[00:00:00, 23:59:59]
End date	Specifies the DST offset end date.	[01-02, 12-30]
End time	Specifies the DST offset end time.	[00:00:00, 23:59:59]
NTP time synchronization	Specifies whether to enable NTP time synchronization.	<ul style="list-style-type: none"> <li>• Disable</li> <li>• Enable</li> </ul>
NTP server address	Specifies the NTP server IP address or domain name.	N/A
NTP server port	Specifies the server port.	[0, 65535]

Parameter	Description	Value Range
NTP time synchronization interval (min)	Specifies the NTP time synchronization interval.	[1, 1440]

## 7.4.6 Comm Config

To access the **Comm config** screen, choose **Comm config** from the **Operation console** screen.

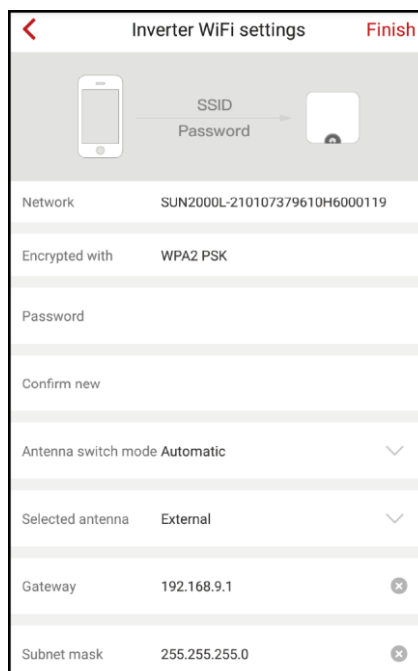
**Figure 7-44** Comm config



### Setting Inverter WiFi Parameters

To set the inverter WiFi parameters, choose **Comm config** > **Inverter WiFi settings** from the **Operation console** screen, and then select the appropriate SUN2000L.

**Figure 7-45** Inverter WiFi settings



**Table 7-13** Description of the parameters on the Inverter WiFi settings screen

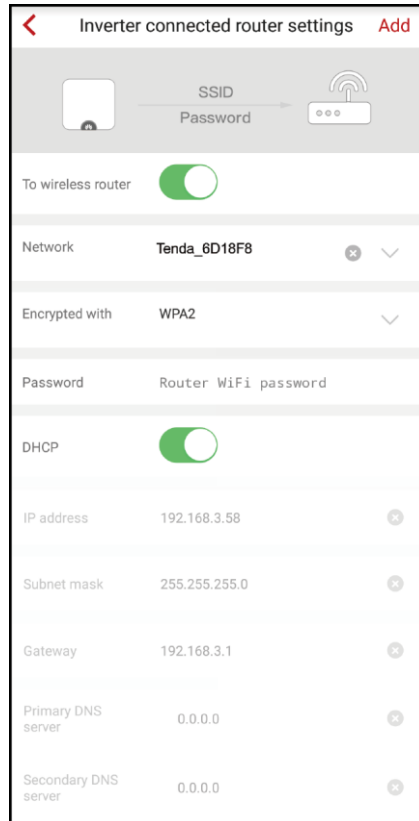
Parameter	Description	Value Range
Network	Specifies the service set identifier (SSID) of the inverter WiFi network that functions as an access point (AP).	N/A
Encrypted with	Specifies the encryption level of the physical layer of the inverter WiFi network.	N/A
Password	Specifies the password for the inverter WiFi network. The initial password is <b>Changeme</b> . To ensure the account security, change the password as soon as possible.	<ul style="list-style-type: none"> <li>The password length must be 8 to 64 characters.</li> <li>The password cannot contain special characters.</li> </ul>
Confirm new		
Antenna switch mode	If this parameter is set to <b>Manual</b> , you can select either the internal or external antenna. If it is set to <b>Automatic</b> , the system automatically detects the signals of the internal antenna and external antenna and selects the one with stronger signals. The detection cycle is 5 minutes.	<ul style="list-style-type: none"> <li>Automatic</li> <li>Manual</li> </ul>
Select antenna	Specifies the embedded or external antenna. (If <b>Antenna switch mode</b> is set to <b>Manual</b> and <b>Select antenna</b> is set to <b>External</b> , ensure that the external antenna is correctly connected.)	<ul style="list-style-type: none"> <li>Embedded</li> <li>External</li> </ul>
Gateway	Specifies the IP address for the inverter WiFi network that functions as an AP. The default value is recommended.	[1.0.0.0, 223.255.255.255]
Subnet mask	The default value ( <b>255.255.255.0</b> ) is recommended.	[0.0.0.0, 255.255.255.255]



## Setting the Router Connected to the SUN2000L

To set the parameters for the router connected to the SUN2000L, choose **Comm config > Inverter connected router settings** from the **Operation console** screen.

**Figure 7-46** Inverter connected router settings



### NOTE

Before the **Inverter WiFi settings screen** is displayed, the app sends a command to start scanning. Then the SUN2000L starts to scan nearby WiFi networks and sends a list of WiFi networks to the app.

**Table 7-14** Description of the parameters on the Inverter connected router settings screen

Parameter	Description	Value Range
To wireless router	Specifies whether to connect the SUN2000L to a router.	<ul style="list-style-type: none"> <li>• Disable</li> <li>• Enable</li> </ul>
Network	Specifies the SSID of the router to which the inverter WiFi network connects.	N/A

Parameter	Description	Value Range
Encrypted with	Specifies the encryption level for the SUN2000L to connect to the router over WiFi. It should be the same as the encryption level of the router.  This parameter is related to the network name.	<ul style="list-style-type: none"> <li>• Not encrypted</li> <li>• WEP_OPEN</li> <li>• WEP_SHARED</li> <li>• WPA</li> <li>• WPA2</li> </ul>
Password	Specifies the WiFi password for the router.	N/A
DHCP	<ul style="list-style-type: none"> <li>• If the IP address automatically assigned by the home router is used, enable this parameter. Then the following parameters will be automatically assigned.</li> <li>• If the IP address automatically assigned by the home router is not used, disable this parameter. Then the following parameters need to be manually assigned.</li> </ul>	<ul style="list-style-type: none"> <li>• Disable</li> <li>• Enable</li> </ul>
IP address	Specifies the IP address for the router to which the inverter WiFi network connects. Recommended: Set the IP address in the same network segment as the home router IP address.	[1.0.0.0, 223.255.255.255]
Subnet mask	Specifies the router subnet mask.	N/A
Gateway	Specifies the router gateway address.	N/A
Primary DNS server	Specifies the address for the primary DNS server.	N/A
Secondary DNS server	Specifies the address for the secondary DNS server.	N/A

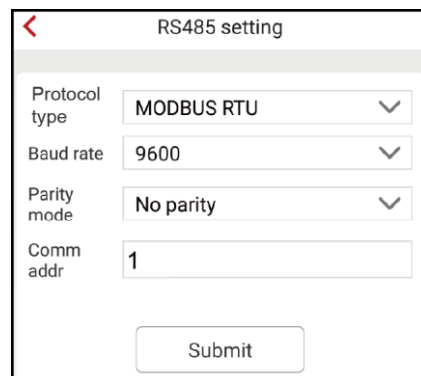
## Setting RS485 Communications Parameters

To set RS485 communications parameters, choose **Comm config > RS485 setting** from the **Operation console** screen.

### NOTE

- If a power meter or battery is connected to the SUN2000L, the baud rate of the SUN2000L should be the same as that of the power meter or battery. Otherwise, the power meter or battery cannot communicate with the SUN2000L.
- The communications address is used only when the SUN2000L connects to the upper-level management unit over RS485.

**Figure 7-47** RS485 setting



**Table 7-15** Description of the parameters on the RS485 setting screen

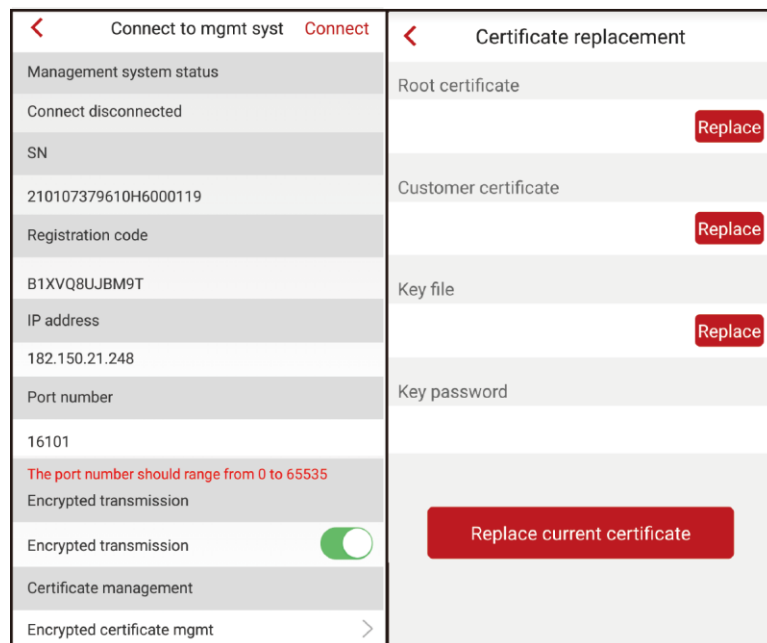
Parameter	Description	Value Range
Protocol type	<ul style="list-style-type: none"> <li>• The SUN2000L can connect to the upper-level management unit over MODBUS RTU, Sunspec, or AVM.</li> <li>• If the SUN2000L connects to an energy meter or battery, set this parameter only to <b>MODBUS RTU</b>.</li> <li>• If the SUN2000L does not communicate over RS485, set this parameter to <b>Invalid protocol type</b>.</li> </ul>	<ul style="list-style-type: none"> <li>• MODBUS RTU</li> <li>• Sunspec</li> <li>• AVM</li> </ul>
Baud rate (bps)	Specifies the RS485 communication rate, which should be the same as the communication baud rate of the energy meter and battery.	<ul style="list-style-type: none"> <li>• 4800</li> <li>• 9600</li> <li>• 19200</li> </ul>

Parameter	Description	Value Range
Parity mode	Specifies the parity mode of RS485 communications, which should be the same as the communication parity mode of the energy meter and battery.	<ul style="list-style-type: none"> <li>No parity</li> <li>Odd parity</li> <li>Even parity</li> </ul>
Comm addr	Specifies the communications address used by the SUN2000L to connect to the upper-level management unit. Keep the address different from the communications address for any other device on the same bus.	[1, 247]

## Configuring the Management System

- To set the management system parameters and connect to the management system, choose **Comm config > Management system settings** from the **Operation console** screen.

**Figure 7-48** Connecting to the management system



**Table 7-16** Description of the parameters on the Connecting to the management system screen

Parameter	Description	Value Range
Management system status	Display the status of the Management system.	N/A
SN	SUN2000L SN.	N/A
Registration code	The installer registration code is generated by the SUN2000L automatically and is used for the installer to register with the management system and manage the inverter.	N/A
IP address	Specifies the IP address or network address used for connecting to the management system.	N/A
Port	Specifies the number of the port on the management system to which the SUN2000L connects over a network protocol. Set this parameter according to the requirements of the accessed management system.	[0, 65535]
Encrypted transmission	<p>If this parameter is enabled, data is transmitted between the SUN2000L and the management system after encrypted with SSL.</p> <p>If this parameter is disabled, data is transmitted between the SUN2000L and the management system as plaintext, which poses security risks.</p>	<ul style="list-style-type: none"> <li>• Disable</li> <li>• Enable</li> </ul>

Parameter	Description	Value Range
Certificate management	If encrypted connection to a third-party network management system is required, replace the client certificate provided by the third party. You can select the appropriate root certificate, customer certificate, or key file and enter the private key password. After the replacement is complete, connect the SUN2000L to the management system and check the correctness of the certificate.	N/A

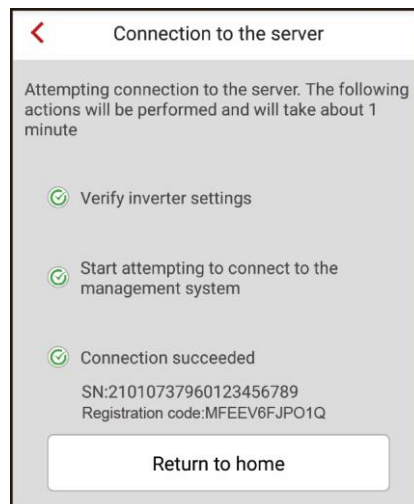
2. Tap **Connect** in the upper right corner. After the management system is successfully connected, the SUN2000L will report the SN and installer registration code. If the connection fails, another connection attempt will start after 10 seconds.



**NOTE**

The installer registration code is generated by the SUN2000L automatically and is used for the installer to register with the management system and manage the inverter.

**Figure 7-49** Connection succeeded



## 7.4.7 Managing Logs

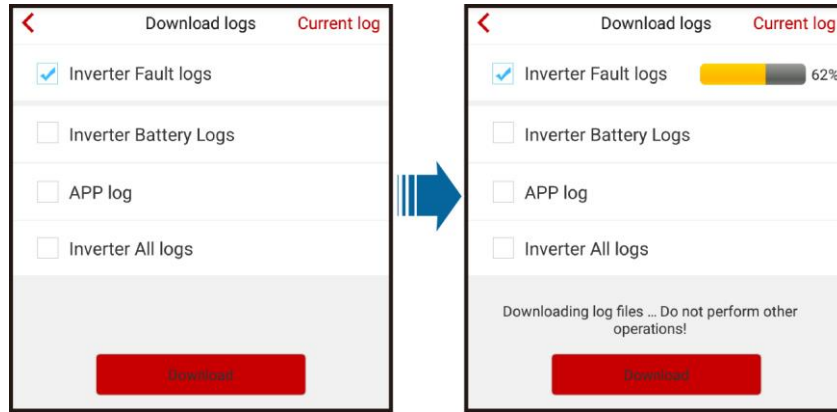
### Context

The ways of downloading all logs and fault logs are the same as the way of downloading battery logs. This section describes how to download all logs.

## Procedure

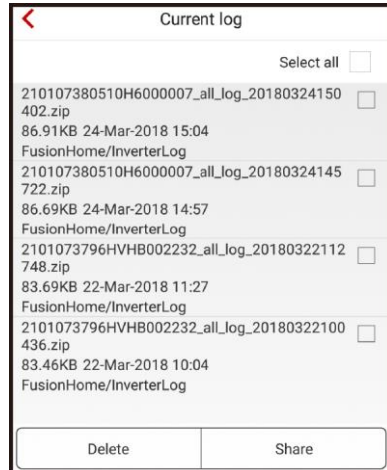
- Step 1** On the **Operation console** screen, choose **Log mgmt** to access the **Download logs** screen, and then download logs by following the instructions.

**Figure 7-50** Downloading logs



- Step 2** After logs are downloaded, choose **Current log** to access the log list, where you can view the downloaded logs. To email or delete logs, tap **Select** in the upper right corner and select the logs that need to be emailed or deleted.

**Figure 7-51** Current log



----End

## 7.4.8 Menu

### 7.4.8.1 Changing the Password

To change the login password for the installer, choose **...** > **Change password** in the upper right corner on the **Operation console** screen.



**NOTE**

The password should meet the following requirements:

- Contains 6–20 characters.
- Contains at least two of the following types: lowercase letters, uppercase letters, and digits.
- Differs from the old password by at least two characters.

**Figure 7-52** Change password

Change password

User name | installer

Old password | Enter the old password

New password | Enter a new password

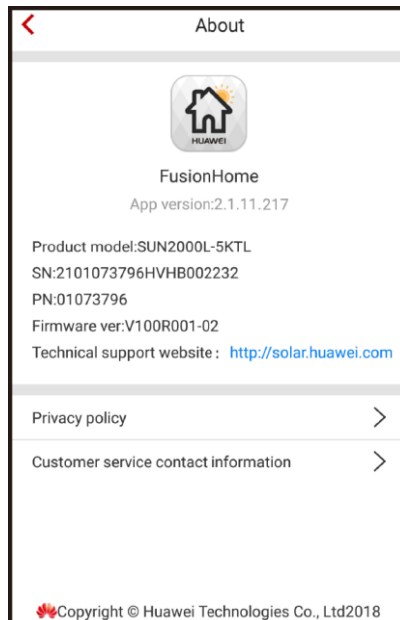
Confirm password | Confirm the new password

CANCEL COMMIT

## 7.4.8.2 About

To view the version information, choose **...** > **About** from the **Operation console** screen.

**Figure 7-53** About





## 7.5 App Operations by the User

### 7.5.1 Logging In to the App

#### Prerequisites

- You have logged in as **installer** and followed the instructions on the **Quick setting** screen.
- The corresponding SUN2000L is displayed on the **Inverter list** screen.

#### Procedure

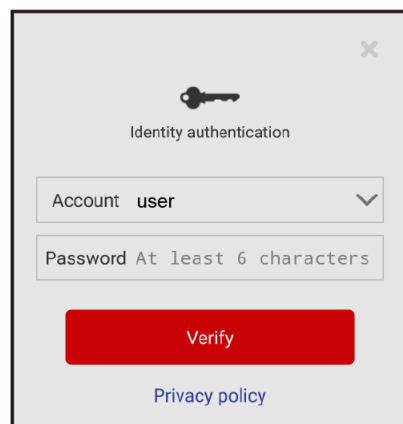
**Step 1** On the **Inverter list** screen, choose **user**, and enter the login password.



#### NOTE

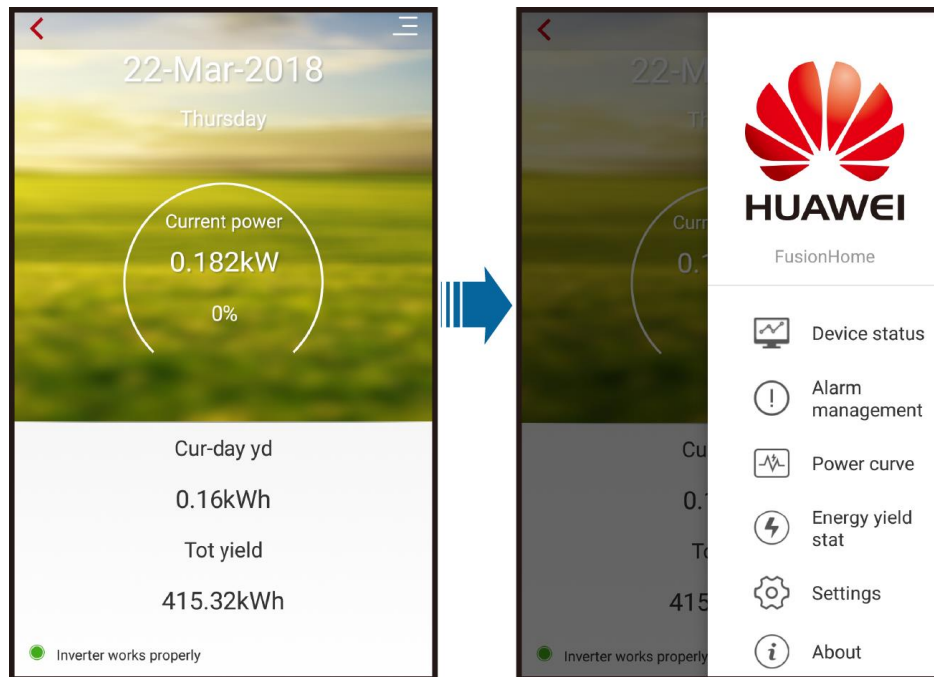
- The name of the connected SUN2000L is represented by its serial number (SN), which is available on the SN label attached to the side of the SUN2000L.
- The login password is the same as that for the SUN2000L connected to the app and is used only when the SUN2000L connects to the app.
- The initial password is **0000a**. Use the initial password upon first login. To ensure account security, change the password immediately after login.
- If you enter wrong passwords for five consecutive times and the interval between two consecutive passwords is within 2 minutes, your account will be locked out for 5 minutes.

**Figure 7-54** Identity authentication



**Step 2** If you log in successfully, the home screen is displayed.

Figure 7-55 Home screen

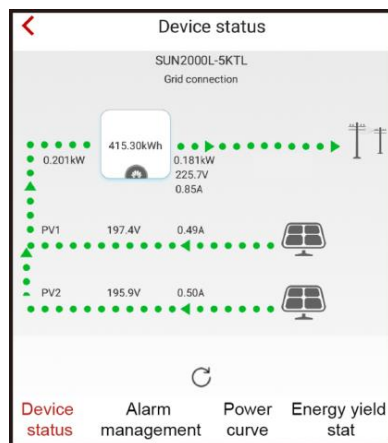


----End

## 7.5.2 Querying the Device Status



To query the status of each device, choose  > **Device status** from the main screen.

Figure 7-56 Querying the device status

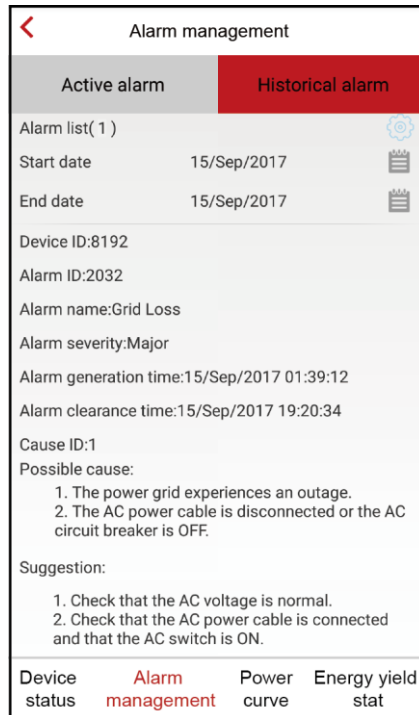


## 7.5.3 Alarm Management

On the home screen, choose  > **Alarm management** to view active and historical alarms.

To set the sorting mode for active alarms or historical alarms, tap . To query the historical alarms within a certain time range, tap  and select the time range.

**Figure 7-57** Alarm management



## 7.5.4 Querying the Power Curve


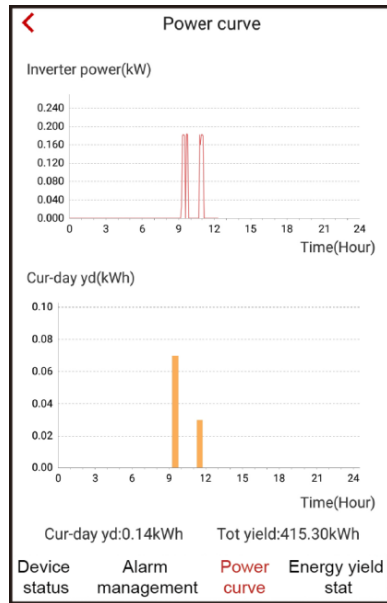
To query the current-day power curve and energy yield, choose  > **Power curve** from the main screen.

Figure 7-58 Power curve



## 7.5.5 Querying Energy Yields


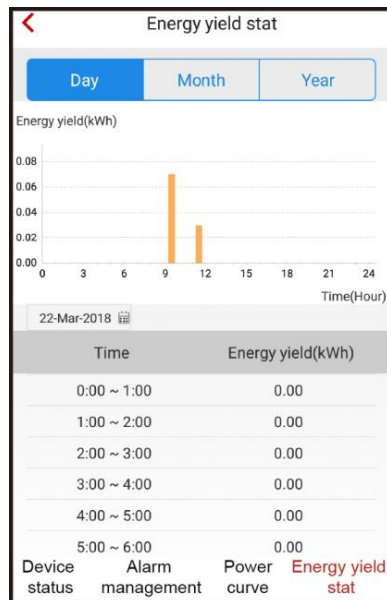

On the main screen, choose  > **Energy yield stat** to query the daily, monthly, and yearly energy yields.

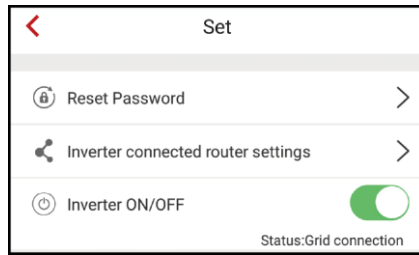
Figure 7-59 Querying energy yields



## 7.5.6 Settings

On the main screen, choose  > **Set** and perform the following operations as required.

**Figure 7-60** Settings



- Reset the password for **user** to log in to the SUN2000L.



**NOTE**

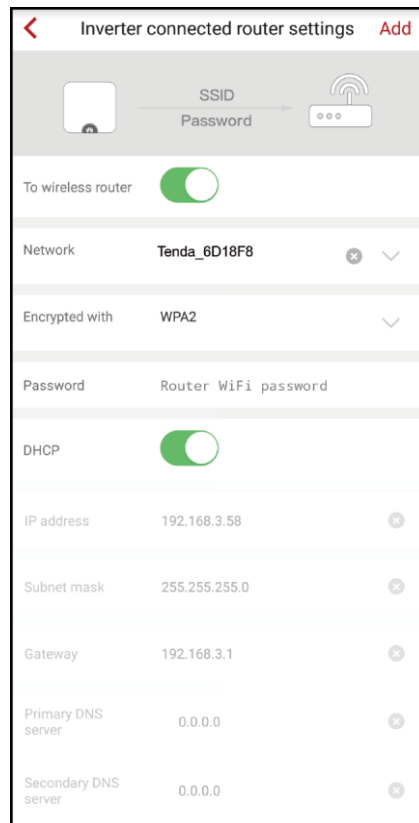
The password should meet the following requirements:

- Contains 6–20 characters.
- Contains at least two of the following types: lowercase letters, uppercase letters, and digits.
- Differs from the old password by at least two characters.

**Figure 7-61** Change password

- Select the router to be connected and set parameters as required.

**Figure 7-62** Inverter connected router settings



**NOTE**

Before the **Inverter WiFi settings screen** is displayed, the app sends a command to start scanning. Then the SUN2000L starts to scan nearby WiFi networks and sends a list of WiFi networks to the app.

**Table 7-17** Description of the parameters on the Inverter connected router settings screen

Parameter	Description	Value Range
To wireless router	Specifies whether to connect the SUN2000L to a router.	<ul style="list-style-type: none"> <li>• Disable</li> <li>• Enable</li> </ul>
Network	Specifies the SSID of the router to which the inverter WiFi network connects.	N/A
Encrypted with	Specifies the encryption level for the SUN2000L to connect to the router over WiFi. It should be the same as the encryption level of the router.  This parameter is related to the network name.	<ul style="list-style-type: none"> <li>• Not encrypted</li> <li>• WEP_OPEN</li> <li>• WEP_SHARED</li> <li>• WPA</li> <li>• WPA2</li> </ul>
Password	Specifies the WiFi password for the router.	N/A

Parameter	Description	Value Range
DHCP	<ul style="list-style-type: none"> <li>If the IP address automatically assigned by the home router is used, enable this parameter. Then the following parameters will be automatically assigned.</li> <li>If the IP address automatically assigned by the home router is not used, disable this parameter. Then the following parameters need to be manually assigned.</li> </ul>	<ul style="list-style-type: none"> <li>Disable</li> <li>Enable</li> </ul>
IP address	Specifies the IP address for the router to which the inverter WiFi network connects. Recommended: Set the IP address in the same network segment as the home router IP address.	[1.0.0.0, 223.255.255.255]
Subnet mask	Specifies the router subnet mask.	N/A
Gateway	Specifies the router gateway address.	N/A
Primary DNS server	Specifies the address for the primary DNS server.	N/A
Secondary DNS server	Specifies the address for the secondary DNS server.	N/A

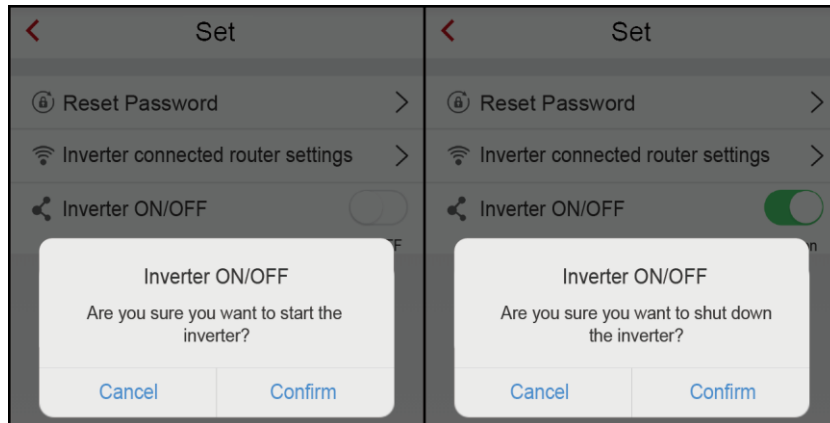
- Start or shut down the SUN2000L.




**NOTE**

To start or shut down the SUN2000, you need to re-enter the password.

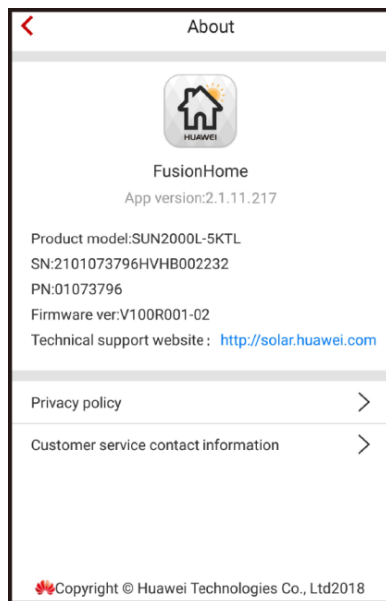
**Figure 7-63** Starting or shutting down the SUN2000L



## 7.5.7 About

To view the version information, choose  > **About** from the main screen.

**Figure 7-64** About





## 7.6 App Troubleshooting

**Table 7-18** Common faults and troubleshooting measures

Symptom	Possible Cause	Measure
The app fails to install on an Android mobile phone.	<ul style="list-style-type: none"> <li>The mobile phone is running a version of the operating system that does not support the FusionHome app.</li> <li><b>Allow Installation of apps from unknown source</b> is not selected.</li> <li>The original version on the mobile phone is not deleted.</li> </ul>	<ul style="list-style-type: none"> <li>Upgrade the mobile phone operating system to a required version.</li> <li>Choose <b>Settings &gt; Security</b> and select <b>Allow Installation of apps from unknown sources</b>.</li> </ul>
The communication fails.	The mobile phone or router is more than 3 meters away from the SUN2000L, so the WiFi is not connected.	Keep the mobile phone or router within 3 meters of the SUN2000L to maintain a reliable WiFi connection.
The <b>Failed to connect to the inverter. Reconnecting...</b> message is displayed.	The mobile phone or router is more than 3 meters away from the SUN2000L, or the WiFi signal is weak.	Ensure that the WiFi network is connected. Log out of the app and then log in again.
All data fails to be obtained during operations.	Connection to the SUN2000L has been interrupted.	Reconnect to the SUN2000L.
The SUN2000L cannot be obtained.	An error has occurred in the WiFi connection to the app.	<ul style="list-style-type: none"> <li>If the list still cannot be obtained after several attempts, log out. Then log in and try again.</li> <li>Check whether the WiFi connection is correct.</li> </ul>
No upgrade package is available for an upgrade.	No upgrade package is saved to the mobile phone.	Save the upgrade package to the mobile phone.

# 8 System Maintenance

## 8.1 Routine Maintenance

To ensure that the SUN2000L can operate properly in the long term, you are advised to perform routine maintenance on it as described in this chapter.



### CAUTION

Before cleaning the system, connecting cables, and maintaining the grounding reliability, power off the system (see [6.3 Powering Off the System](#) for details).

**Table 8-1** Maintenance checklist

Check Item	Acceptance Criteria	Maintenance Interval
System cleanliness	The heat sinks are free from obstacles or dust.	Once every 6 to 12 months
System running status	<ul style="list-style-type: none"><li>The SUN2000L is not damaged or deformed.</li><li>The SUN2000L operates with no abnormal sound.</li><li>All SUN2000L parameters are correctly set. Perform this check when the SUN2000L is running.</li></ul>	Once every 6 months
Electrical connections	<ul style="list-style-type: none"><li>Cables are securely connected.</li><li>Cables are intact, and in particular, the cable jackets touching the metallic surface are not scratched.</li><li>Unused DC input terminals, battery terminals, COM ports, ALARM ports, and ANT ports are locked by watertight caps.</li></ul>	Perform the first maintenance 6 months after the initial commissioning. From then on, perform the maintenance once every 6 to 12 months.

Check Item	Acceptance Criteria	Maintenance Interval
Grounding reliability	Ground cables are securely connected.	Perform the first maintenance 6 months after the initial commissioning. From then on, perform the maintenance once every 6 to 12 months.

## 8.2 Troubleshooting

Alarm severities are defined as follows:

- Major: The SUN2000L enters Shutdown mode and disconnects from the power grid to stop generating power after a fault occurs.
- Minor: Some components are faulty but the SUN2000L can still connect to the power grid and generate power.
- Warning: The SUN2000L output power decreases due to external factors.

**Table 8-2** Common alarms and troubleshooting measures

Alarm ID	Alarm Name	Alarm Severity	Possible Cause	Suggestion
2001	High String Input Voltage	Major	The PV array is incorrectly configured. Excessive PV modules are connected in series to the PV string, and therefore the open-circuit voltage exceeds the maximum inverter input voltage.	<p>Reduce the number of PV modules connected in series to the PV string until the PV string open-circuit voltage is less than or equal to the maximum inverter input voltage. After the PV array is correctly configured, the inverter alarm disappears.</p> <p>The following is the mapping between PV strings and alarm cause IDs:</p> <ul style="list-style-type: none"> <li>• Cause ID 1: string 1</li> <li>• Cause ID 2: string 2</li> </ul>

Alarm ID	Alarm Name	Alarm Severity	Possible Cause	Suggestion
2011	String Reversed	Major	The PV string is reversely connected.	<p>Check whether the PV string is reversely connected to the SUN2000L. If so, wait until the solar irradiance declines at night and the PV string current reduces to below 0.5 A. Then, turn off the DC switch and correct the PV string polarity.</p> <p>The following is the mapping between PV strings and alarm cause IDs:</p> <ul style="list-style-type: none"> <li>• Cause ID 1: string 1</li> <li>• Cause ID 2: string 2</li> </ul>
2032	Grid Failure	Major	<p>Cause ID = 1</p> <ul style="list-style-type: none"> <li>• The power grid experiences an outage.</li> <li>• The AC circuit is disconnected or AC switch is off.</li> </ul>	<ol style="list-style-type: none"> <li>1. Check the AC voltage.</li> <li>2. Check that the AC power cable is connected and that the AC switch is ON.</li> </ol>
2033	Grid Undervoltage	Major	<p>Cause ID = 1</p> <p>The grid voltage is below the lower threshold or the low voltage duration has lasted for more than the value specified by LVRT.</p>	<ol style="list-style-type: none"> <li>1. If the alarm occurs accidentally, the power grid may be abnormal temporarily. The SUN2000L automatically recovers after detecting that the power grid becomes normal.</li> <li>2. If the alarm occurs frequently, check whether the grid voltage is within the acceptable range. If not, contact the local power operator. If so, modify the power grid overvoltage and undervoltage protection thresholds with the consent of the local power operator.</li> <li>3. If the fault persists for a long time, check the connection between the AC switch and the output power cable.</li> </ol>

Alarm ID	Alarm Name	Alarm Severity	Possible Cause	Suggestion
2034	Grid Overvoltage	Major	<p>Cause ID = 1</p> <p>The grid voltage exceeds the higher threshold or the high voltage duration has lasted for more than the value specified by HVRT.</p>	<ol style="list-style-type: none"> <li>1. Check whether the grid connection voltage exceeds the upper threshold. If so, contact the local power operator.</li> <li>2. If you have confirmed that the grid connection voltage exceeds the upper threshold and obtained the consent of the local power operator, modify the overvoltage and undervoltage protection thresholds.</li> <li>3. Check whether the peak grid voltage exceeds the upper threshold.</li> </ol>
2035	Unbalanced Grid Voltage	Major	<p>The difference between grid phase voltages exceeds the upper threshold.</p>	<ol style="list-style-type: none"> <li>1. Check that the grid voltage is within the normal range.</li> <li>2. Check the connection of the AC output power cable.</li> <li>3. If the cable connection is proper but the alarm occurs frequently and affects the power production of the PV plant, contact the local power operator.</li> </ol>
2036	Grid Overfrequency	Major	<p>Cause ID = 1</p> <p>Power grid exception: The actual grid frequency is higher than the local power grid standard.</p>	<ol style="list-style-type: none"> <li>1. If the alarm occurs accidentally, the power grid may be abnormal temporarily. The SUN2000L automatically recovers after detecting that the power grid becomes normal.</li> <li>2. If the alarm occurs frequently, check whether the grid frequency is within the acceptable range. If not, contact the local power operator. If so, modify the grid overfrequency protection threshold with the consent of the local power operator.</li> </ol>

Alarm ID	Alarm Name	Alarm Severity	Possible Cause	Suggestion
2037	Grid Underfrequency	Major	Cause ID = 1 Power grid exception: The actual grid frequency is lower than the local power grid standard.	<ol style="list-style-type: none"> <li>1. If the alarm occurs accidentally, the power grid may be abnormal temporarily. The SUN2000L automatically recovers after detecting that the power grid becomes normal.</li> <li>2. If the alarm occurs frequently, check whether the grid frequency is within the acceptable range. If not, contact the local power operator. If so, modify the grid underfrequency protection threshold with the consent of the local power operator.</li> </ol>
2038	Unstable Grid Frequency	Major	Cause ID = 1 Power grid exception: The actual grid frequency change rate does not comply with the local power grid standard.	<ol style="list-style-type: none"> <li>1. If the alarm occurs accidentally, the power grid may be abnormal temporarily. The SUN2000L automatically recovers after detecting that the power grid becomes normal.</li> <li>2. If the alarm occurs frequently, check whether the grid frequency is within the acceptable range. If not, contact the local power operator.</li> </ol>
2039	Output Overcurrent	Major	Cause ID = 1 The grid voltage drops dramatically or the power grid is short-circuited. As a result, the inverter transient output current exceeds the upper threshold and therefore the inverter protection is triggered.	<ol style="list-style-type: none"> <li>1. The SUN2000L monitors its external working conditions in real time. The SUN2000L automatically recovers after the fault is rectified.</li> <li>2. If the alarm occurs frequently and affects the power production of the PV plant, check whether the output is short-circuited. If the fault persists, contact your supplier.</li> </ol>
2040	Output DC Component Overhigh	Major	Cause ID = 1 The DC component of the SUN2000L output current exceeds the specified upper threshold.	<ol style="list-style-type: none"> <li>1. The SUN2000L monitors its external working conditions in real time. The SUN2000L automatically recovers after the fault is rectified.</li> <li>2. If the alarm occurs frequently, contact your supplier.</li> </ol>

Alarm ID	Alarm Name	Alarm Severity	Possible Cause	Suggestion
2051	Abnormal Residual Current	Major	Cause ID = 1 The insulation impedance of the input side to PE decreases when the SUN2000L is operating.	<ol style="list-style-type: none"> <li>If the alarm occurs accidentally, the external power cable may be abnormal temporarily. The SUN2000L automatically recovers after the fault is rectified.</li> <li>If the alarm occurs frequently or persists, check whether the impedance between the PV string and ground is below the lower threshold.</li> </ol>
2061	Abnormal Grounding	Major	Cause ID = 1 <ul style="list-style-type: none"> <li>The PE cable for the SUN2000L is not connected.</li> <li>The voltage between the SUN2000L neutral wire and ground exceeds the upper threshold.</li> </ul>	<ol style="list-style-type: none"> <li>Check that the PE cable for the SUN2000L is connected properly.</li> <li>Check that the voltage between the SUN2000L neutral wire and ground is within the normal range. If an isolation transformer is connected, set <b>OFF due to abnormal grounding to Disable</b> by referring to <a href="#">7.4.5.3 Feature Parameters</a>.</li> </ol>
2062	Low Insulation Resistance	Major	Cause ID = 1 <ul style="list-style-type: none"> <li>The PV string is short-circuited to PE.</li> <li>The PV string is installed in a moist environment for a long time.</li> </ul>	<ol style="list-style-type: none"> <li>Check the impedance between the PV array output and PE, and eliminate short circuits and poor insulation points.</li> <li>Check that the SUN2000L PE cable is correctly connected.</li> <li>If you confirm that the impedance is less than the default value in a cloudy or rainy environment, reset <b>Insulation resistance protection</b>.</li> </ol>
2063	Overtemperature	Major	Cause ID = 1 <ul style="list-style-type: none"> <li>The SUN2000L is installed in a place with poor ventilation.</li> <li>The ambient temperature exceeds the upper threshold.</li> <li>The SUN2000L is not working properly.</li> </ul>	<ul style="list-style-type: none"> <li>Check the ventilation and ambient temperature at the SUN2000L installation position.</li> <li>If the ventilation is poor or the ambient temperature exceeds the upper threshold, improve the ventilation and heat dissipation.</li> <li>If both the ventilation and ambient temperature meet requirements, contact your supplier.</li> </ul>
2064	Device Fault	Major	Cause ID = 1–12 An unrecoverable fault occurs on a circuit inside the SUN2000L.	Turn off the AC output switch and DC input switch, and then turn them on after 5 minutes. If the fault persists, contact your supplier.

Alarm ID	Alarm Name	Alarm Severity	Possible Cause	Suggestion
2065	Upgrade Failed	Major	Cause ID = 1-4 The upgrade does not end normally.	<ol style="list-style-type: none"> <li>1. Perform an upgrade again.</li> <li>2. If the upgrade fails several times, contact your supplier.</li> <li>3. Check that the DC power supply is connected.</li> </ol>
61440	Monitoring Unit Faulty	Minor	Cause ID = 1 The communication module is faulty.	Contact your supplier to rectify the fault.
2067	Faulty Power Collector	Major	Cause ID = 1 <ul style="list-style-type: none"> <li>• In Grid Connection with Zero Power mode, the energy meter communication is interrupted.</li> <li>• In Maximum Use of Self-Produced Power mode, the energy meter communication is interrupted.</li> </ul>	<ol style="list-style-type: none"> <li>1. Check that the preset energy meter model is the same as the actual model.</li> <li>2. Check that the preset communications parameters for the energy meter are the same as the actual configurations.</li> <li>3. Check that the energy meter is powered on and the RS485 communications cable is correctly connected.</li> </ol>
2068	Battery Abnormal	Minor	Cause ID = 1 <ul style="list-style-type: none"> <li>• The battery is faulty.</li> <li>• The battery communication is interrupted.</li> <li>• The battery switch trips when the SUN2000L is running.</li> </ul>	<ol style="list-style-type: none"> <li>1. Check that the communications cable and power cable between the SUN2000L and the battery are properly connected.</li> <li>2. Check that the battery switch is turned on properly.</li> <li>3. Turn off the AC output switch, DC input switch, and battery switch, and then turn them on after 5 minutes. If the fault persists, contact your supplier.</li> </ol>
2075	Peripheral Port Short Circuit	Warning	Cause ID = 1 The SUN2000L Alarm port is short-circuited when supplying 12 V power to peripheral.	<ol style="list-style-type: none"> <li>1. Turn off the AC and DC switches on the SUN2000L and disconnect the peripheral from the Alarm port. Then power on the SUN2000L again and clear the alarm manually. If the alarm persists, contact your supplier to rectify the fault. If the alarm is cleared, it indicates that the port on the SUN2000L is normal. Then check that the pins in the power port on the peripheral are not short-circuited.</li> <li>2. Replace the peripheral, and then start a self-check to check that the port functions properly.</li> </ol>





**NOTE**

Contact your supplier if all failure analysis procedures listed above are completed and the fault still exists.

# 9 Handling the SUN2000L

---

## 9.1 Removing the SUN2000L

### Procedure

- Step 1** Power off the system by following the instructions in [6.3 Powering Off the System](#).
  - Step 2** Disconnect all cables from the SUN2000L, including signal cables, DC input power cables, battery cables, AC output power cables, and PE cables.
  - Step 3** Remove the WiFi antenna from the SUN2000L.
  - Step 4** Remove the SUN2000L from the mounting bracket.
  - Step 5** Remove the mounting bracket.
- End

## 9.2 Packing the SUN2000L

- If the original packaging is available, put the SUN2000L inside it and then seal it using adhesive tape.
- If the original packaging is not available, put the SUN2000L inside a suitable cardboard box and seal it properly.

## 9.3 Disposing of the SUN2000L

If the SUN2000L service life expires, dispose of it according to the local disposal rules for electrical equipment and electronic component waste.

# 10 Technical Specifications

## Efficiency

Item	SUN2000L-2KTL	SUN2000L-3KTL	SUN2000L-3.68KTL	SUN2000L-4KTL	SUN2000L-4.6KTL	SUN2000L-5KTL
Maximum efficiency	98.4%	98.5%	98.5%	98.6%	98.6%	98.6%
European weighted efficiency	97%	97.6%	97.8%	97.9%	98%	98%

## Input

Item	SUN2000L-2KTL	SUN2000L-3KTL	SUN2000L-3.68KTL	SUN2000L-4KTL	SUN2000L-4.6KTL	SUN2000L-5KTL
Maximum input voltage <sup>a</sup>	<ul style="list-style-type: none"> <li>600 V (No battery connects to the SUN2000L.)</li> <li>495 V (An LG-RESU battery connects to the SUN2000L.)</li> </ul>					
Maximum input current (per MPPT)	11 A					
Maximum short-circuit current (per MPPT)	15 A					
Maximum inverter backfeed current to the PV array	0 A					
Operating voltage range	<ul style="list-style-type: none"> <li>90–500 V (No battery connects to the SUN2000L.)</li> <li>90–495 V (An LG-RESU battery connects to the SUN2000L.)</li> </ul>					

Item	SUN2000L-2KTL	SUN2000L-3KTL	SUN2000L-3.68KTL	SUN2000L-4KTL	SUN2000L-4.6KTL	SUN2000L-5KTL
Start voltage range	<ul style="list-style-type: none"> <li>120–600 V (No battery connects to the SUN2000L.)</li> <li>120–495 V (An LG-RESU battery connects to the SUN2000L.)</li> </ul>					
MPPT voltage range	<ul style="list-style-type: none"> <li>90–500 V (No battery connects to the SUN2000L.)</li> <li>90–425 V (An LG-RESU battery connects to the SUN2000L.)</li> </ul>					
Full load MPPT voltage range <sup>b</sup>	120–480 V	160–480 V	190–480 V	210–480 V	260–480 V	260–480 V
Rated input voltage	380 V					
Number of inputs	2					
Number of MPP trackers	2					
	<ul style="list-style-type: none"> <li>Note a: Maximum input voltage includes the voltage of PV and battery inputs.</li> <li>Note b: The full load MPPT voltage is 425 V when an LG-RESU battery connects to the SUN2000L.</li> </ul>					

## Output

Item	SUN2000L-2KTL	SUN2000L-3KTL	SUN2000L-3.68KTL	SUN2000L-4KTL	SUN2000L-4.6KTL	SUN2000L-5KTL
Rated output power <sup>a</sup>	2000 W	3000 W	3680 W	4000 W	4600 W	5000 W
Maximum apparent power <sup>b</sup>	2200 VA	3300 VA	3680 VA	4400 VA	5000 VA	5500 VA
Rated output voltage	220 V/230 V/240 V					
Adapted grid frequency	50 Hz/60 Hz					
Maximum output current <sup>c</sup>	10 A	15 A	16 A	20 A	23 A	25 A
Power factor	0.8 leading... 0.8 lagging					
Maximum total harmonic distortion (rated power)	≤ 3%					

Item	SUN2000L-2KTL	SUN2000L-3KTL	SUN2000L-3.68KTL	SUN2000L-4KTL	SUN2000L-4.6KTL	SUN2000L-5KTL
	<ul style="list-style-type: none"> <li>Note a: The maximum output power of the SUN2000L-5KTL is 4990 W if the Australian AS4777 grid code is selected.</li> <li>Note b: The maximum apparent power of the SUN2000L-4.6KTL is 4600 VA if the Germany VDE-AR-N 4105 grid code is selected. The maximum apparent power of the SUN2000L-4.6KTL and SUN2000L-5KTL is 4990 VA if the Australian AS4777 grid code is selected.</li> <li>Note c: The maximum output current of the SUN2000L-4.6KTL and SUN2000L-5KTL is 21.7 A if the Australian AS4777 grid code is selected.</li> </ul>					

## Protection

Item	SUN2000L-2KTL	SUN2000L-3KTL	SUN2000L-3.68KTL	SUN2000L-4KTL	SUN2000L-4.6KTL	SUN2000L-5KTL
Anti-islanding protection	Supported					
Input reverse polarity protection	Supported					
Output short-circuit protection	Supported					
RCMU	Supported					
AC surge protection	Supported					
DC surge protection	Supported					
Output overvoltage protection	Supported					
Insulation resistance detection	Supported					

## Communication

Item	SUN2000L-2KTL	SUN2000L-3KTL	SUN2000L-3.68KTL	SUN2000L-4KTL	SUN2000L-4.6KTL	SUN2000L-5KTL
Display	LED					
WiFi	Supported					

Item	SUN2000L-2KTL	SUN2000L-3KTL	SUN2000L-3.68KTL	SUN2000L-4KTL	SUN2000L-4.6KTL	SUN2000L-5KTL
RS485	Supported					

### Common parameters

Item	SUN2000L-2KTL	SUN2000L-3KTL	SUN2000L-3.68KTL	SUN2000L-4KTL	SUN2000L-4.6KTL	SUN2000L-5KTL
Topology	Transformerless					
Ingress Protection Rating	IP65					
Cooling mode	Natural cooling					
Dimensions (W x H x D)	375 mm x 375 mm x 117 mm (excluding the mounting plate)/375 mm x 375 mm x 149.5 mm (including the mounting plate)/440 mm x 440mm x 231mm (including the package)					
Weight	11.6 kg (including the mounting plate)/13.8kg (including the package)					
Operating temperature	-30 °C to +60 °C (derated above +45 °C)					
Humidity	0%–100% RH					
Operating altitude	0–4000 m (derated above 2000 m)					

# A Grid Codes

 **NOTE**

Grid codes are subject to change. The listed codes are for your reference only.

**Table A-1** Grid codes (SUN2000L-2KTL/SUN2000L-3KTL)

No.	Grid Code	Description	Grid Voltage	Grid Frequency
1	VDE-AR-N-4105	Germany low-voltage power grid	230 V	50 Hz
2	NB/T 32004	China Golden Sun low-voltage power grid	220 V	50 Hz
3	UTE C 15-712-1(A)	France mainland power grid	230 V	50 Hz
4	UTE C 15-712-1(B)	France island power grid (50 Hz)	230 V	50 Hz
5	UTE C 15-712-1(C)	France island power grid (60 Hz)	230 V	60 Hz
6	G83-England	England 230 V power grid (I < 16 A)	230 V	50 Hz
7	G83-Scotland	Scotland 240 V power grid (I < 16 A)	240 V	50 Hz
8	CEI0-21	Italy power grid	230 V	50 Hz
9	EN50438-NL	Netherlands power grid	230 V	50 Hz
10	AS4777	Australia power grid	230 V	50 Hz
11	IEC61727	IEC61727	230 V	50 Hz

No.	Grid Code	Description	Grid Voltage	Grid Frequency
		low-voltage power grid (50 Hz)		
12	EN50438-TR	Turkey low-voltage power grid	230 V	50 Hz
13	IEC61727-60Hz	IEC61727 low-voltage power grid (60 Hz)	230 V	60 Hz
14	CLC/TS50549_IE	Ireland power grid	230 V	50 Hz

**Table A-2** Grid codes (SUN2000L-3.68KTL)

No.	Grid Code	Description	Grid Voltage	Grid Frequency
1	VDE-AR-N-4105	Germany low-voltage power grid	230 V	50 Hz
2	UTE C 15-712-1(A)	France mainland power grid	230 V	50 Hz
3	UTE C 15-712-1(B)	France island power grid (50 Hz)	230 V	50 Hz
4	UTE C 15-712-1(C)	France island power grid (60 Hz)	230 V	60 Hz
5	G83-England	England 230 V power grid (I < 16 A)	230 V	50 Hz
6	G83-Scotland	Scotland 240 V power grid (I < 16 A)	240 V	50 Hz
7	CEI0-21	Italy power grid	230 V	50 Hz
8	EN50438-NL	Netherlands power grid	230 V	50 Hz
9	AS4777	Australia power grid	230 V	50 Hz
10	IEC61727	IEC61727 low-voltage power grid (50 Hz)	230 V	50 Hz
11	EN50438-TR	Turkey low-voltage power grid	230 V	50 Hz



No.	Grid Code	Description	Grid Voltage	Grid Frequency
12	IEC61727-60Hz	IEC61727 low-voltage power grid (60 Hz)	230 V	60 Hz
13	CLC/TS50549_IE	Ireland power grid	230 V	50 Hz

**Table A-3** Grid codes (SUN2000L-4KTL)

No.	Grid Code	Description	Grid Voltage	Grid Frequency
1	VDE-AR-N-4105	Germany low-voltage power grid	230 V	50 Hz
2	NB/T 32004	China Golden Sun low-voltage power grid	220 V	50 Hz
3	UTE C 15-712-1(A)	France mainland power grid	230 V	50 Hz
4	UTE C 15-712-1(B)	France island power grid (50 Hz)	230 V	50 Hz
5	UTE C 15-712-1(C)	France island power grid (60 Hz)	230 V	60 Hz
6	G59-England	England 230 V power grid (I > 16 A)	230 V	50 Hz
7	G59-Scotland	Scotland 240 V power grid (I > 16 A)	240 V	50 Hz
8	CEI0-21	Italy power grid	230 V	50 Hz
9	EN50438-NL	Netherlands power grid	230 V	50 Hz
10	AS4777	Australia power grid	230 V	50 Hz
11	IEC61727	IEC61727 low-voltage power grid (50 Hz)	230 V	50 Hz
12	EN50438-TR	Turkey low-voltage power grid	230 V	50 Hz
13	IEC61727-60Hz	IEC61727 low-voltage power	230 V	60 Hz

No.	Grid Code	Description	Grid Voltage	Grid Frequency
		grid (60 Hz)		
14	CLC/TS50549_IE	Ireland power grid	230 V	50 Hz

**Table A-4** Grid codes (SUN2000L-4.6KTL)

No.	Grid Code	Description	Grid Voltage	Grid Frequency
1	VDE-AR-N-4105	Germany low-voltage power grid	230 V	50 Hz
2	UTE C 15-712-1(A)	France mainland power grid	230 V	50 Hz
3	UTE C 15-712-1(B)	France island power grid (50 Hz)	230 V	50 Hz
4	UTE C 15-712-1(C)	France island power grid (60 Hz)	230 V	60 Hz
5	G59-England	England 230 V power grid (I > 16 A)	230 V	50 Hz
6	G59-Scotland	Scotland 240 V power grid (I > 16 A)	240 V	50 Hz
7	CEI0-21	Italy power grid	230 V	50 Hz
8	EN50438-NL	Netherlands power grid	230 V	50 Hz
9	AS4777	Australia power grid	230 V	50 Hz
10	IEC61727	IEC61727 low-voltage power grid (50 Hz)	230 V	50 Hz
11	EN50438-TR	Turkey low-voltage power grid	230 V	50 Hz
12	IEC61727-60Hz	IEC61727 low-voltage power grid (60 Hz)	230 V	60 Hz
13	CLC/TS50549_IE	Ireland power grid	230 V	50 Hz

**Table A-5** Grid codes (SUN2000L-5KTL)

No.	Grid Code	Description	Grid Voltage	Grid Frequency
1	UTE C 15-712-1(A)	France mainland power grid	230 V	50 Hz
2	NB/T 32004	China Golden Sun low-voltage power grid	220 V	50 Hz
3	UTE C 15-712-1(A)	France mainland power grid	230 V	50 Hz
4	UTE C 15-712-1(B)	France island power grid (50 Hz)	230 V	50 Hz
5	UTE C 15-712-1(C)	France island power grid (60 Hz)	230 V	60 Hz
6	G59-England	England 230 V power grid (I > 16 A)	230 V	50 Hz
7	G59-Scotland	Scotland 240 V power grid (I > 16 A)	240 V	50 Hz
8	CEI0-21	Italy power grid	230 V	50 Hz
9	EN50438-NL	Netherlands power grid	230 V	50 Hz
10	AS4777	Australia power grid	230 V	50 Hz
11	IEC61727	IEC61727 low-voltage power grid (50 Hz)	230 V	50 Hz
12	EN50438-TR	Turkey low-voltage power grid	230 V	50 Hz
13	IEC61727-60Hz	IEC61727 low-voltage power grid (60 Hz)	230 V	60 Hz
14	CLC/TS50549_IE	Ireland power grid	230 V	50 Hz

# B Acronyms and Abbreviations

---

## A

**AC** alternating current

## D

**DC** direct current

## I

**ID** identifier

## L

**LED** light emitting diode

**LVRT** low voltage ride-through

## M

**MAC** Media Access Control

**MPPT** maximum power point tracking

## P

**PC** personal computer

**PE** protective earthing

**PV** photovoltaic

## R

<b>RCD</b>	residual current device
<b>RCMU</b>	residual current monitoring unit
<b>RH</b>	relative humidity
<b>S</b>	
<b>SN</b>	serial number
<b>T</b>	
<b>THDi</b>	total distortion of the input current waveform
<b>W</b>	
<b>WEEE</b>	waste electrical and electronic equipment
<b>WiFi</b>	Wireless Fidelity